

# 4942335COM 6 Drawer Dresser

Date of Purchase \_\_\_ / \_\_\_ / \_\_\_  
Lot Number:

B344942335COM1

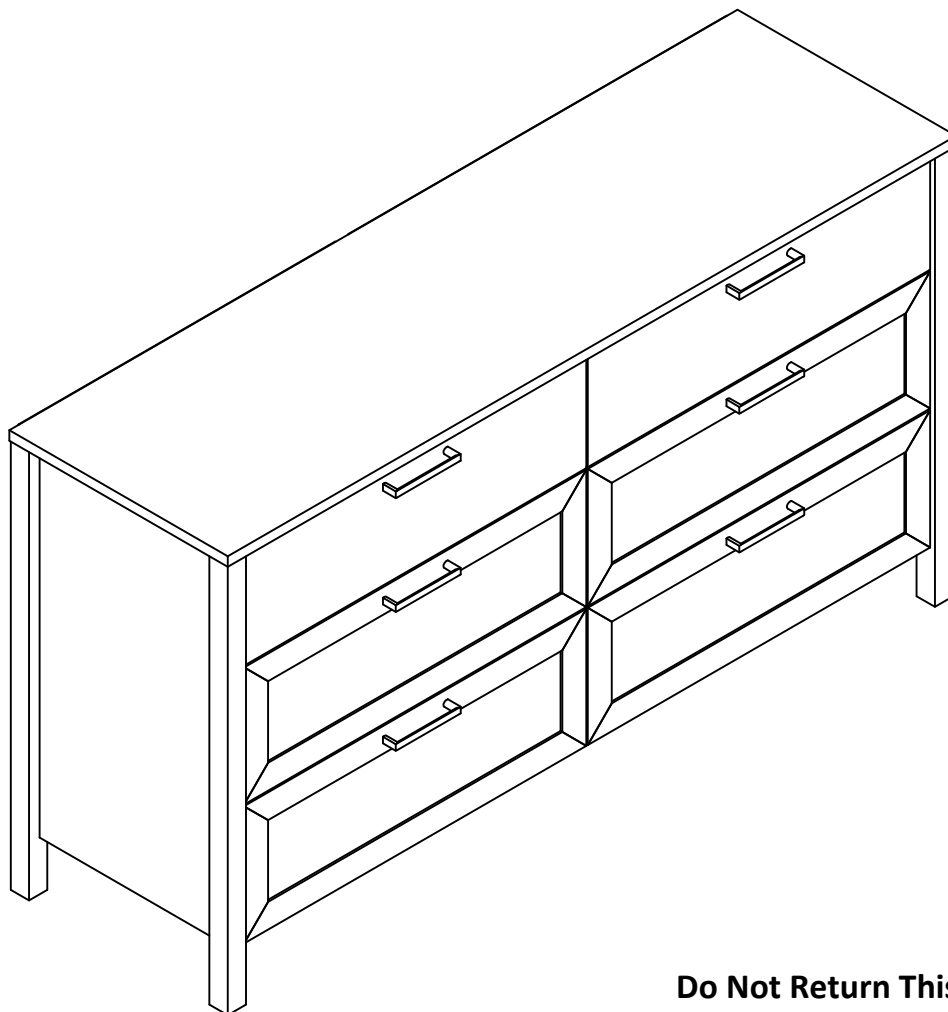

**Do Not Return This Product!**  
Contact our customer service team for help first.  
**Call: 1-800-489-3351 (toll free)**  
**Visit:**  
[www.ameriwoodhome.com](http://www.ameriwoodhome.com)

THIS INSTRUCTION BOOKLET CONTAINS **IMPORTANT** SAFETY INFORMATION. PLEASE READ AND KEEP FOR FUTURE REFERENCE.

Keep your home and family safe with the wall anchor kit that is included with the product.

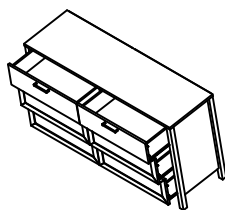

Serious or fatal crushing injuries can occur from tipping furniture.

**WARNING: Manufacturer assumes no liability for improper installation or excessive loads placed on screws or bracket. This wall anchor is not a substitute for proper adult supervision.**



# Contact Us!

## Do NOT return this product!

Contact our friendly customer service team first for help.

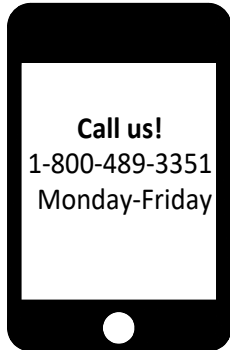

Visit [ameriwoodhome.com](http://ameriwoodhome.com) to view the limited warranty valid in the U.S. and Canada.

Assembly Tips



# Helpful Hints

PEOPLE NEEDED FOR ASSEMBLY: **1-2**  
ESTIMATED ASSEMBLY TIME: **2 HOURS**

- Open your item in the area you plan to keep it to avoid excessive heavy lifting.
- Identify, sort and count the parts before attempting assembly.
- Compression dowels are lightly tapped in with a hammer.
- Slides are labeled with a **R** (right) and **L** (left) for proper placement.
- Make sure to always face the point on the top of the Cam Lock towards the outer edge.
- Use all the nails provided for the back panel and spread them out equally.
- Back panel must be used to make sure your unit is sturdy.
- Do NOT use harsh chemicals or abrasive cleaners on this item.
- Never push, pull, or drag your furniture.



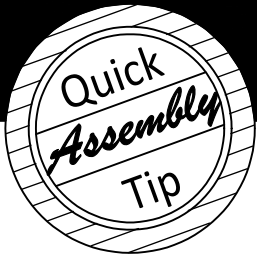

# Before You Start

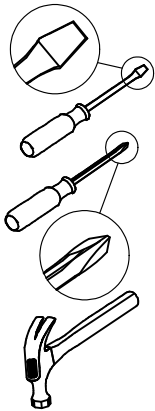

- ✓ Read through each step carefully and follow the proper order
- ✓ Separate and count all your parts and hardware
- ✓ Give yourself enough room for the assembly process
- ✓ Have the following tools: Flat Head Screwdriver, #2 Phillips Head Screwdriver and Hammer
- ✓ Caution: If using a power drill or power screwdriver for screwing, please be aware to slow down and stop when screw is tight. Failure to do so may result in stripping the screw.

# Cam Lock Fastening System

This Cam Lock Fastening System will be used throughout the assembly process.

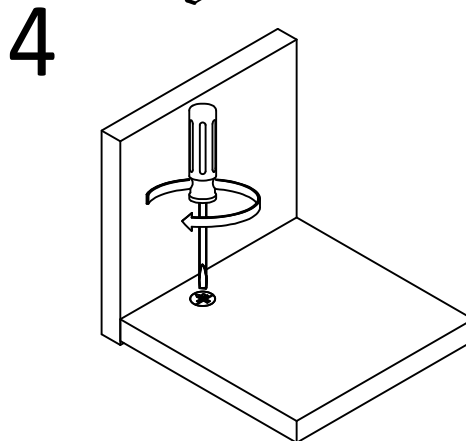
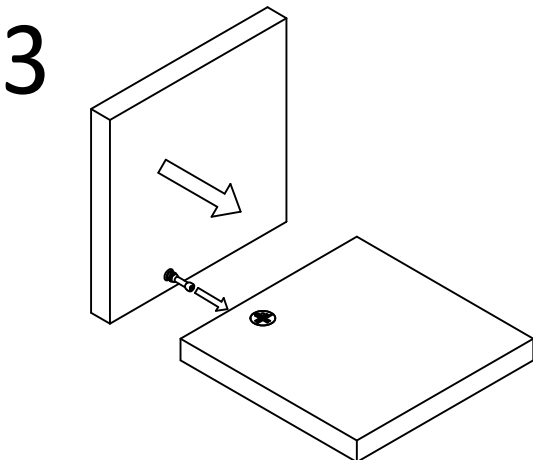
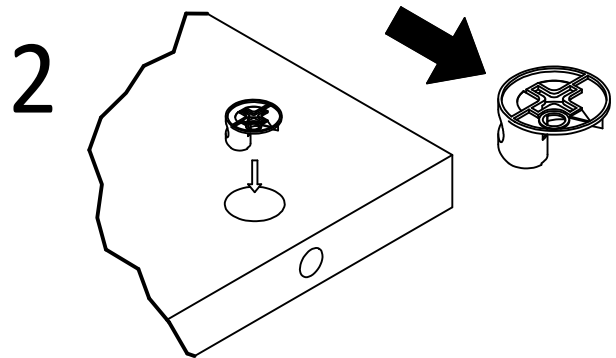
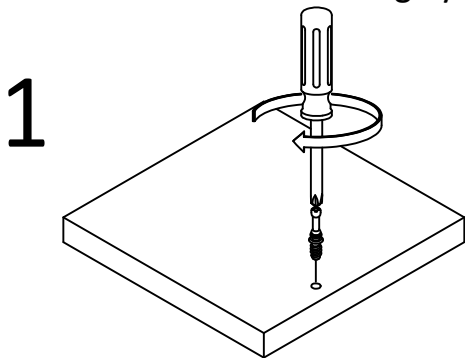

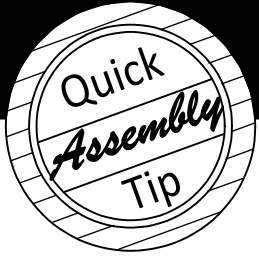

# Before You Start

Please Note:

You may need to lightly tap the wood dowels to insert into the holes during your assembly process.

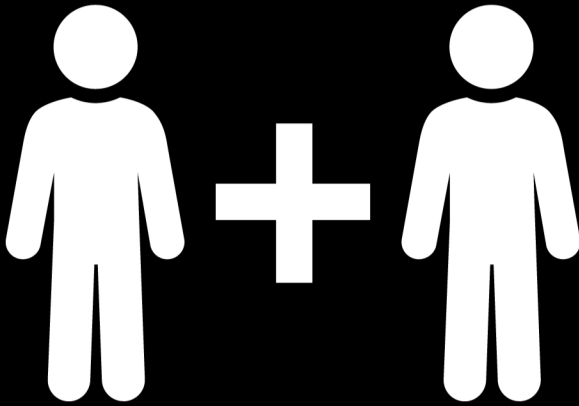
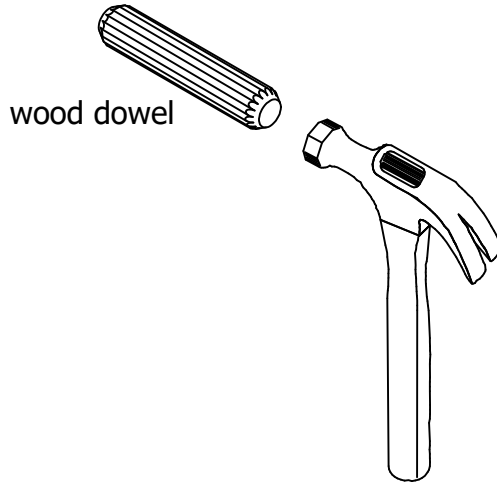

**2 PEOPLE NEEDED FOR ASSEMBLY**

**2 PERSONAS NECESITADAS  
PARA LA ASAMBLEA**

**2 PERSONNES NÉCESSAIRES  
POUR L'ASSEMBLAGE**

**CAUTION:** Failure to use 2 people for assembly could result in unit damage or personal injury.

**PRECAUCIÓN:** Si no se utilizan 2 personas para el ensamblaje, se pueden producir daños en la unidad o lesiones personales.

**ATTENTION:** Échec d'utiliser 2 personnes pour l'assemblage peut causer du dommage au meuble ou causer des blessures.

# Board Identification

Not actual size

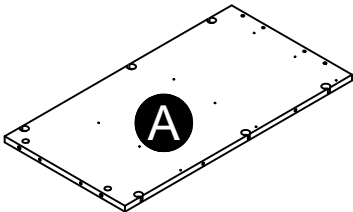

Left Panel  
34942335010

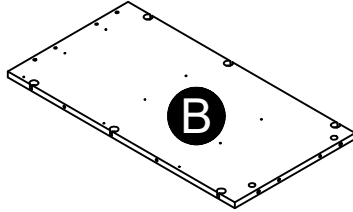

Right Panel  
34942335020

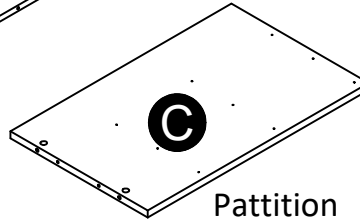

Partition  
34942335030

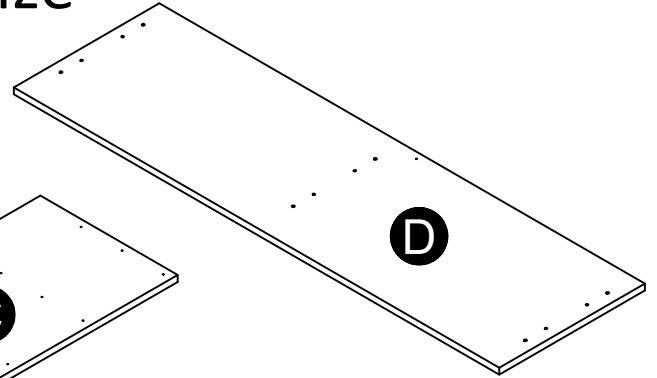

Top  
34942335041

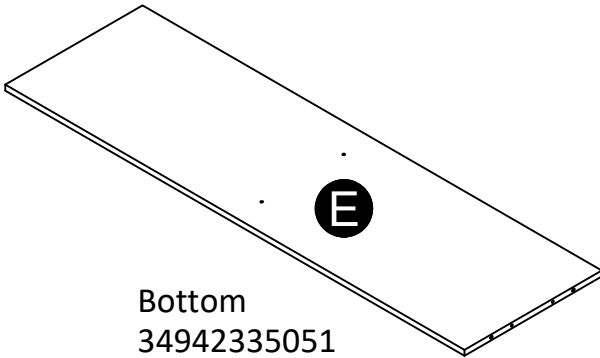

Bottom  
34942335051

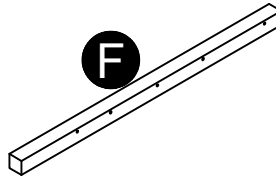

Left Front Leg  
34942335060

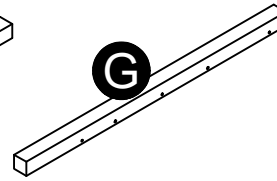

Right Front Leg  
34942335070

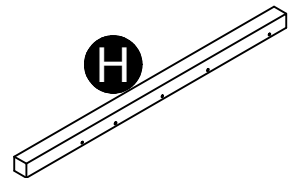

Left Rear Leg  
34942335080

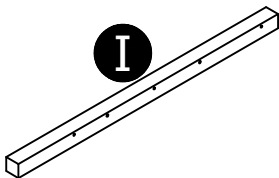

Right Rear Leg  
34942335090

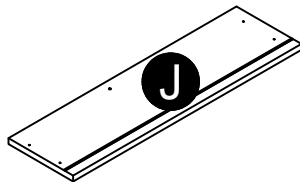

Left Upper Drawer Front  
34942335100

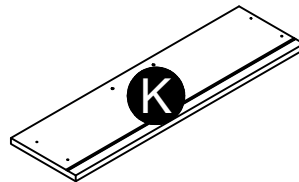

Right Upper Drawer Front  
34942335110

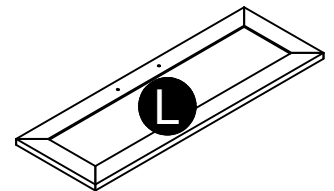

Left Lower Drawer Front (x2)  
34942335120

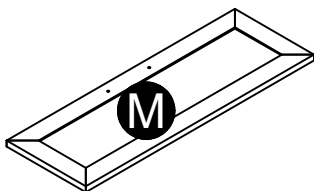

Right Lower Drawer Front (x2)  
34942335130



Drawer Side (x12)  
39991167346200C

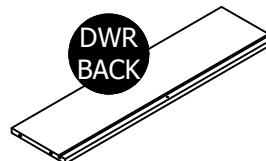

Drawer Back (x6)  
39991167065490B

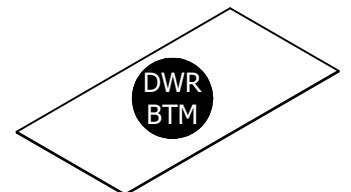

Drawer Bottom (x6)  
39991338066610D

# Board Identification

Not actual size

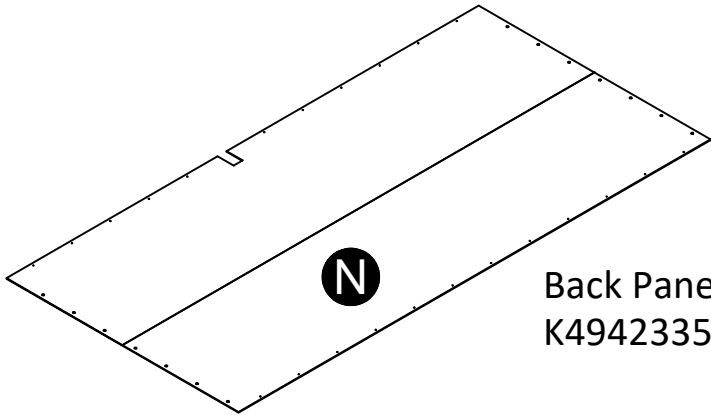

Back Panel  
K494233500

This piece is paperboard construction.  
It is not made from wood, but is  
required for the assembly of your unit.

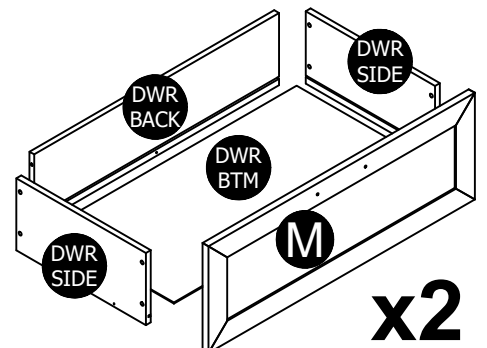
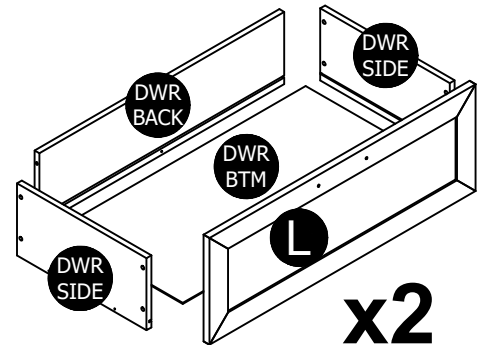
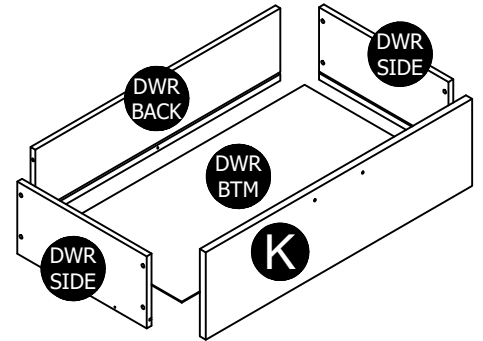
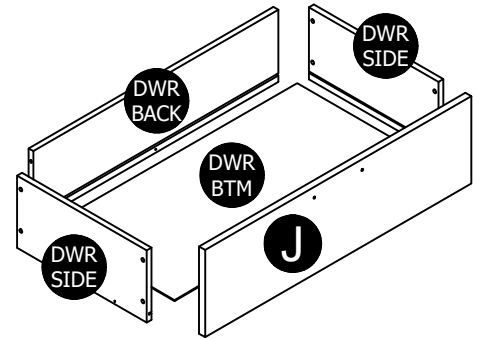
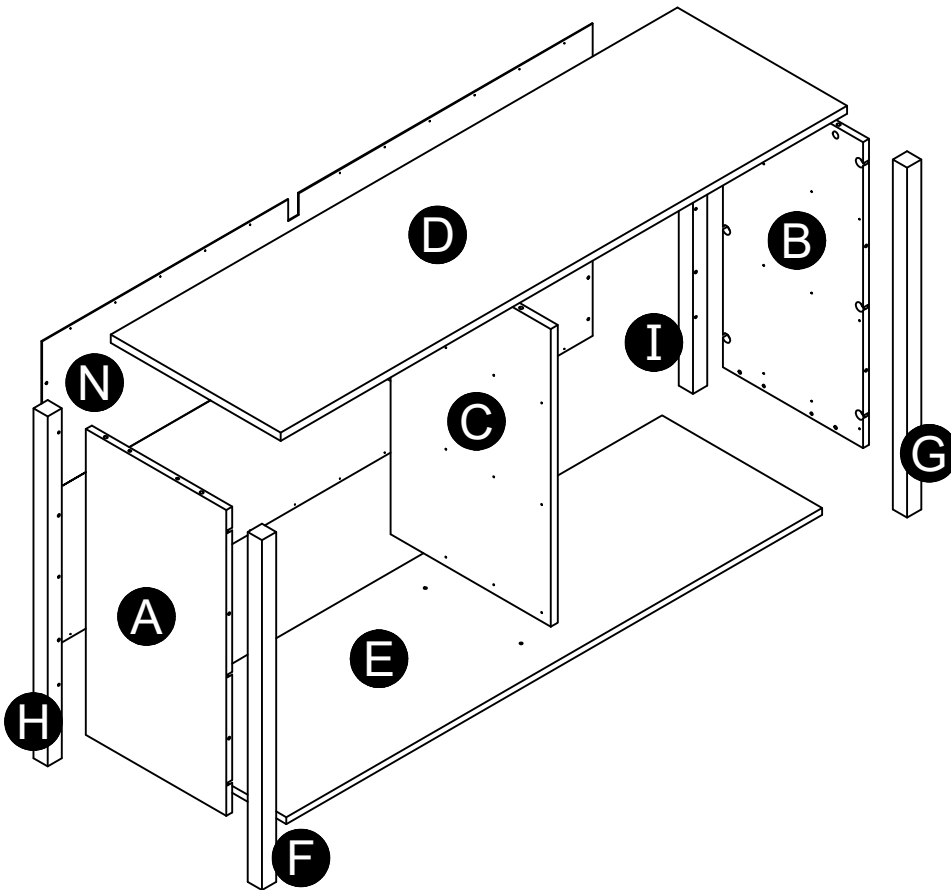

# Part List

Actual Size

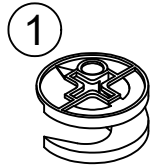

(x10)  
#A22620  
cam lock

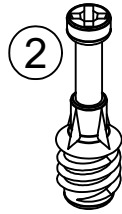

(x10)  
#A22610  
cam bolt

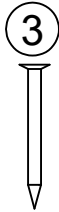

(x23)  
#A21110  
nail

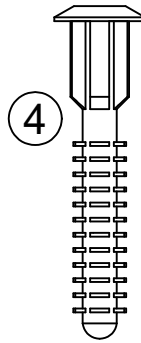

(x24)  
#A21970  
drive fastener



(x74)  
#A12120  
#8 x 7/16" screw



(x12)  
#A22910  
connector bolt

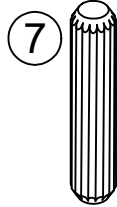

(x18)  
#A21660  
wood dowel

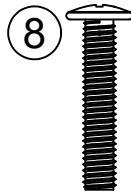

(x12)  
#A17400  
8-32 x 7/8" truss

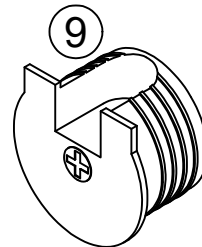

(x12)  
#A22920  
connector

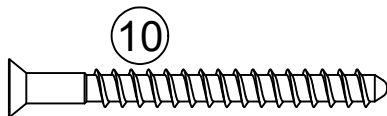

(x2)  
#A23030  
confirmat screw



(x60)  
#A11080  
#6 x 7/16" screw

# Part List

Not Actual Size

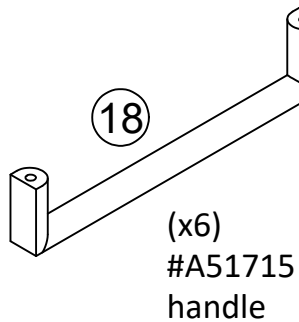
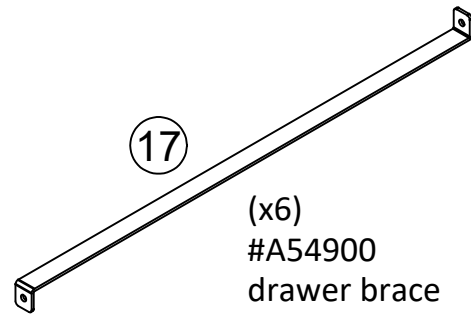
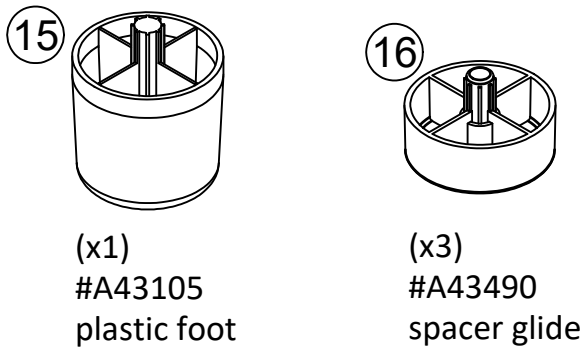
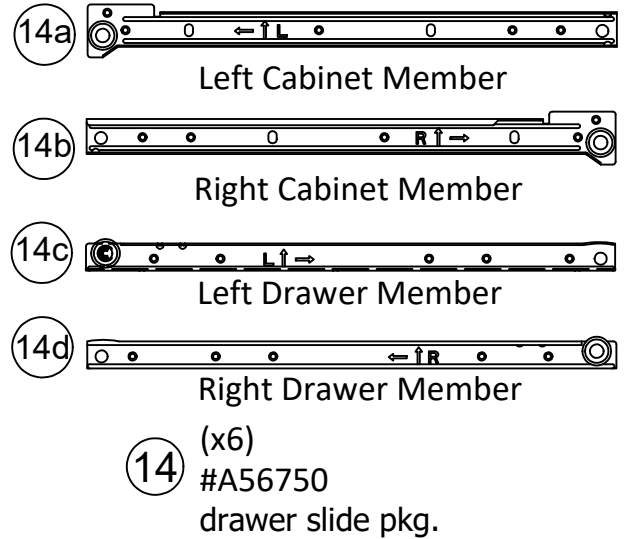
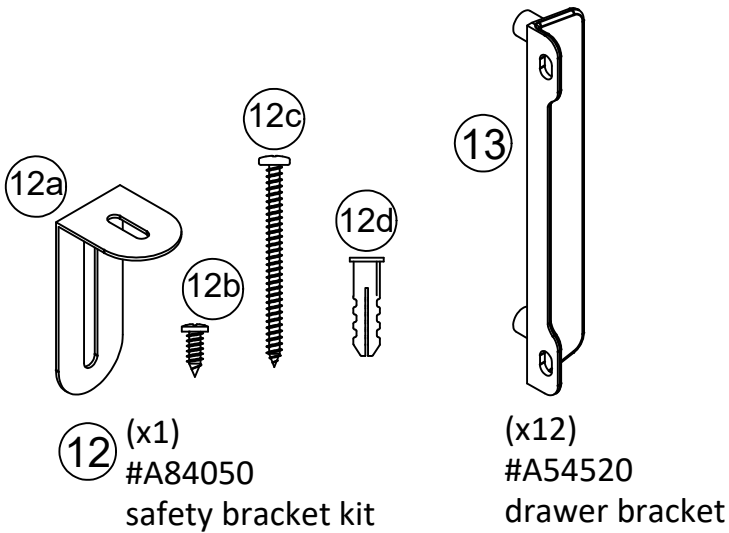



# STEP 1

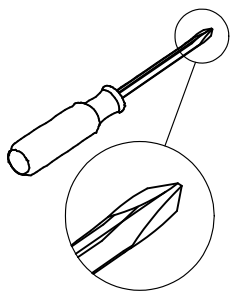

6  
(x12)  
#A22910

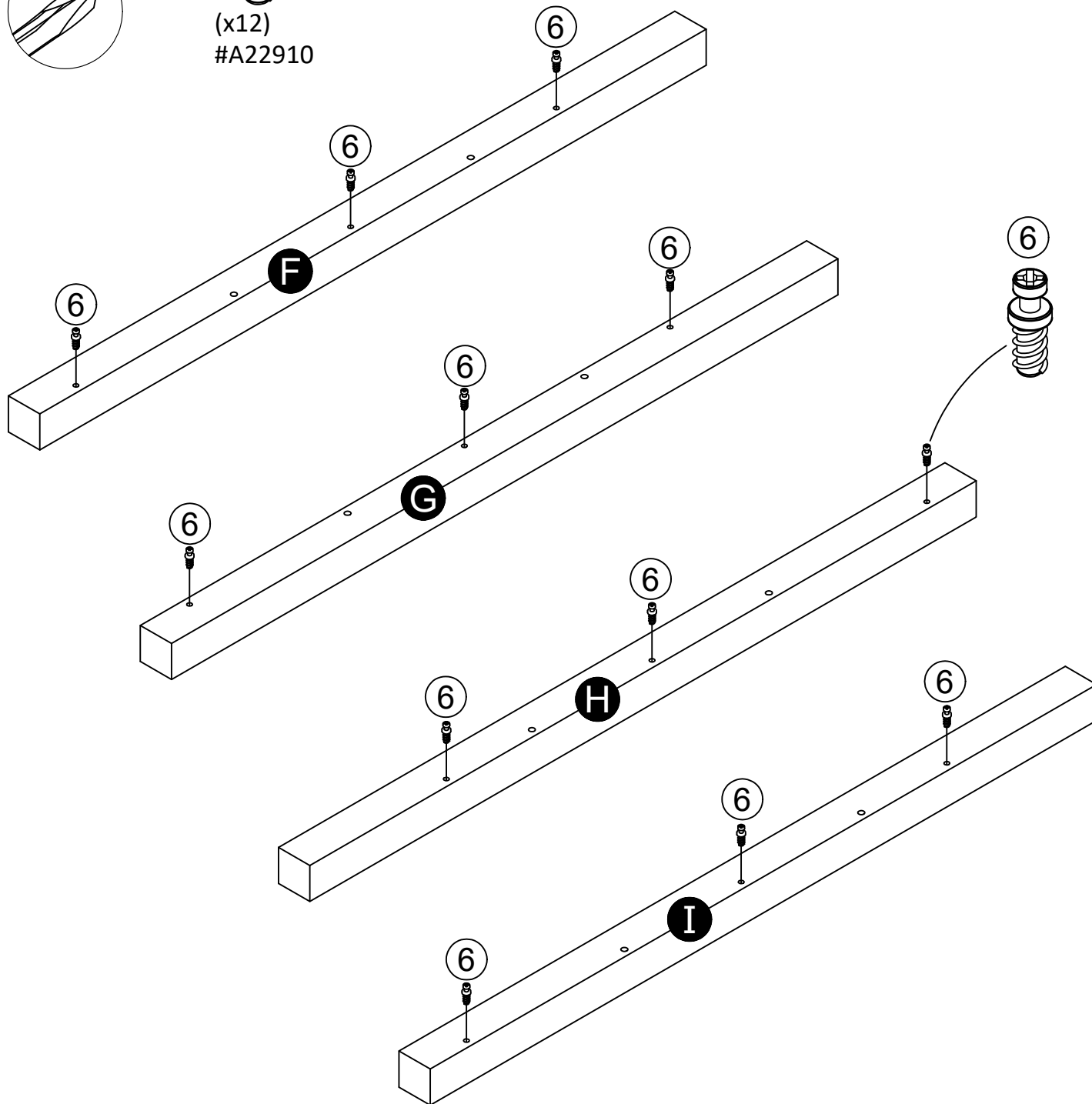

# STEP 2

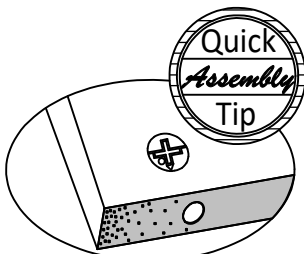
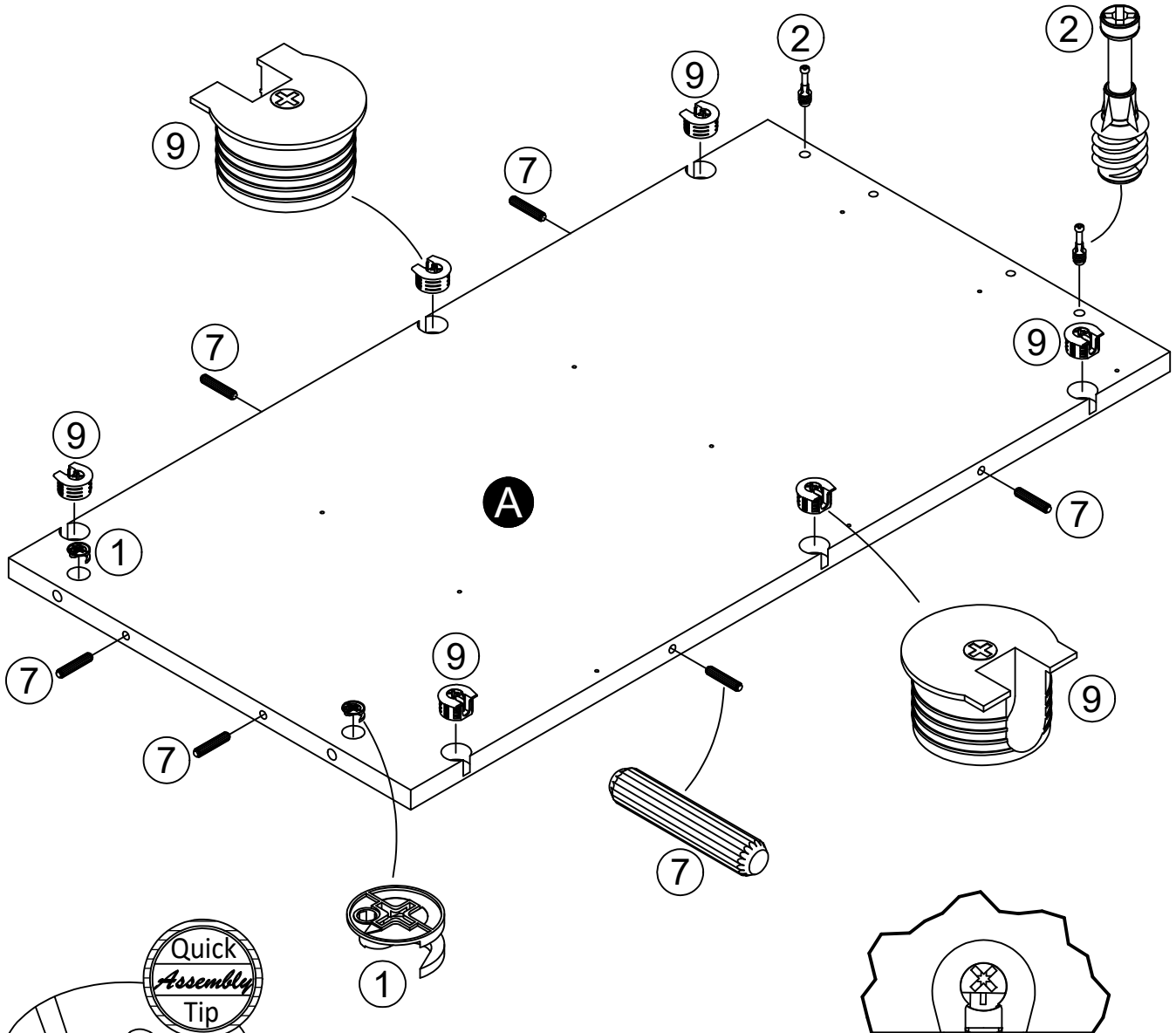
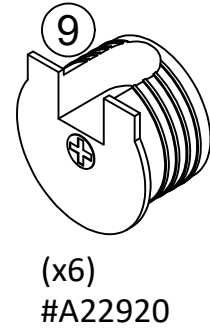
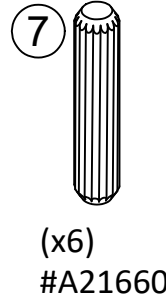
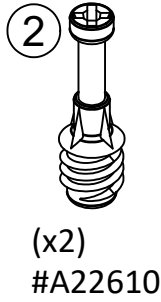
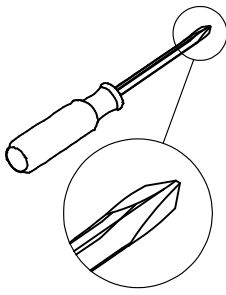
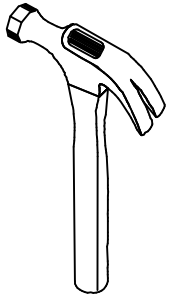

Proper orientation of CAM LOCK

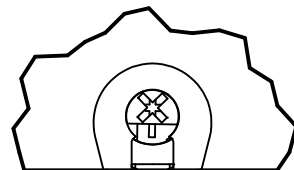

You will need to tap the connector (9) with a hammer to fully insert. Be sure the connector is positioned as shown before tapping into hole.

# STEP 3

---

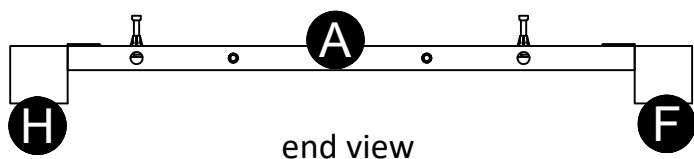
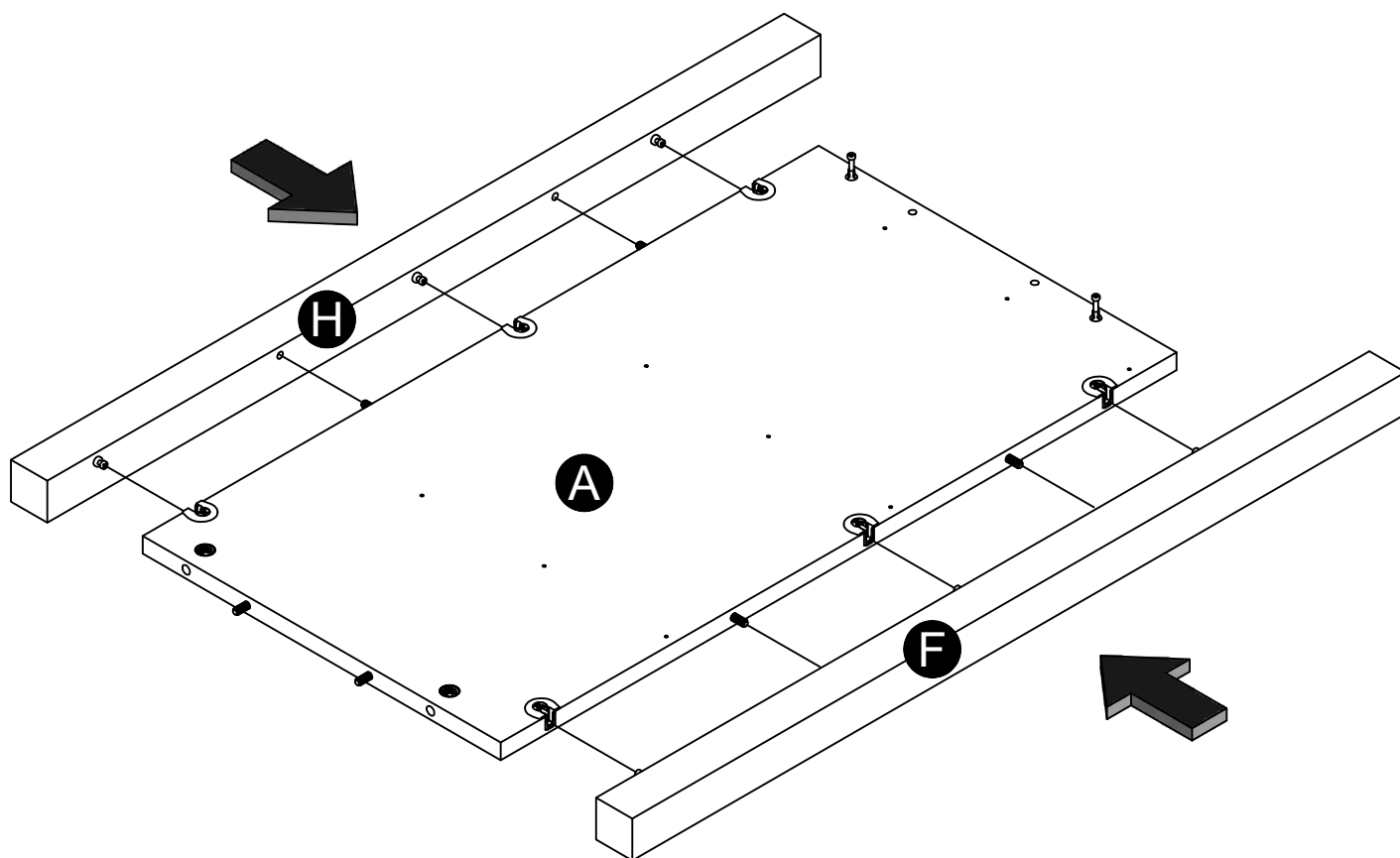
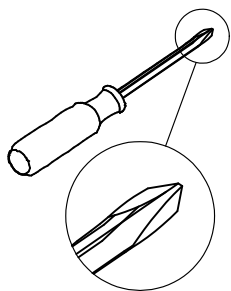

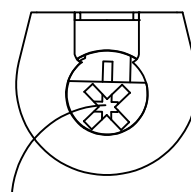

end view

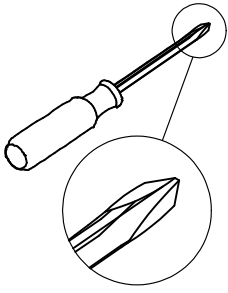

Turn screw clockwise  
to lock in place.

# STEP 4



(11)  
  
(x9)  
#A11080

(14a)  Marked with a "L"  
Left Cabinet Member  
(x3)  
#A56750

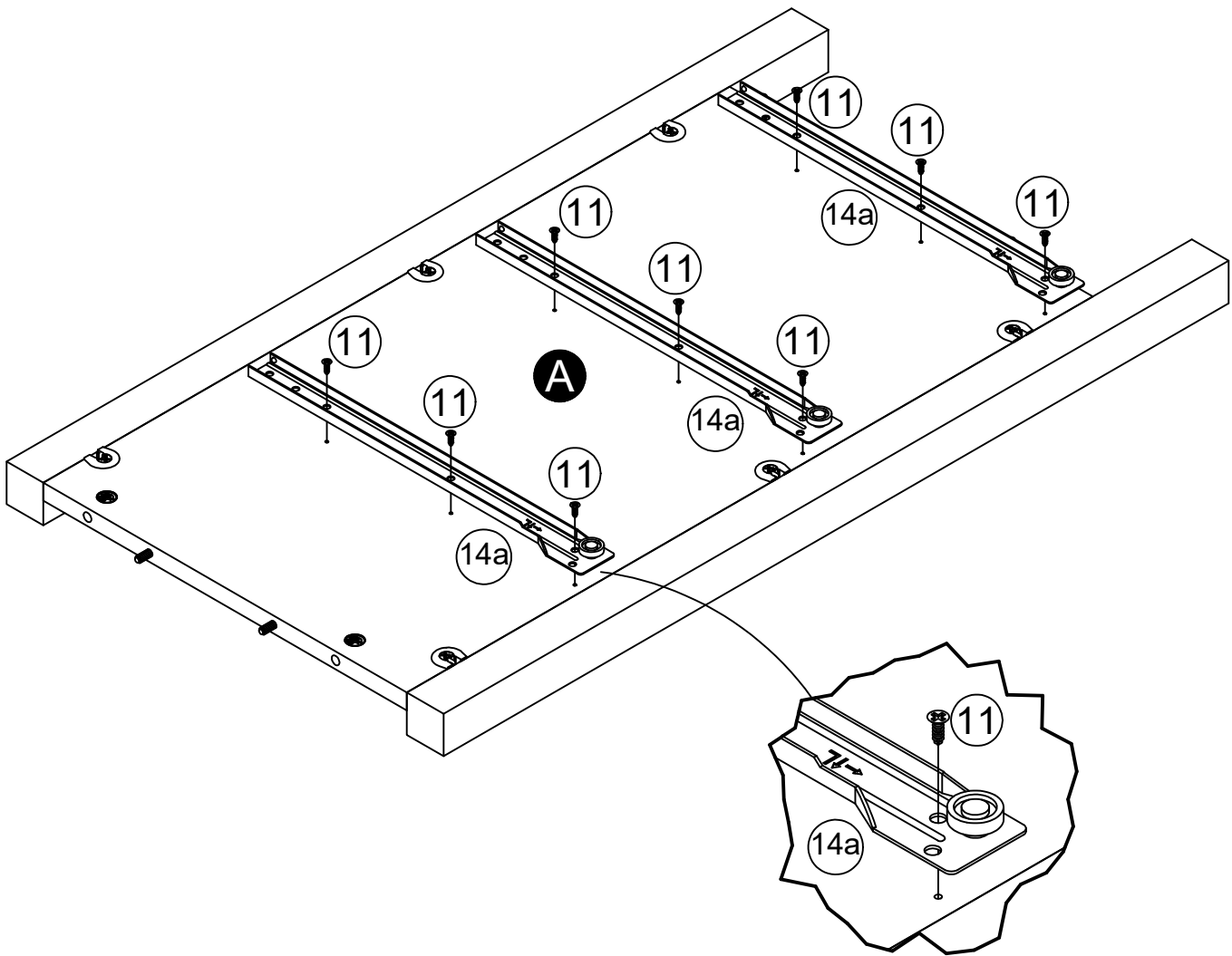

# STEP 5

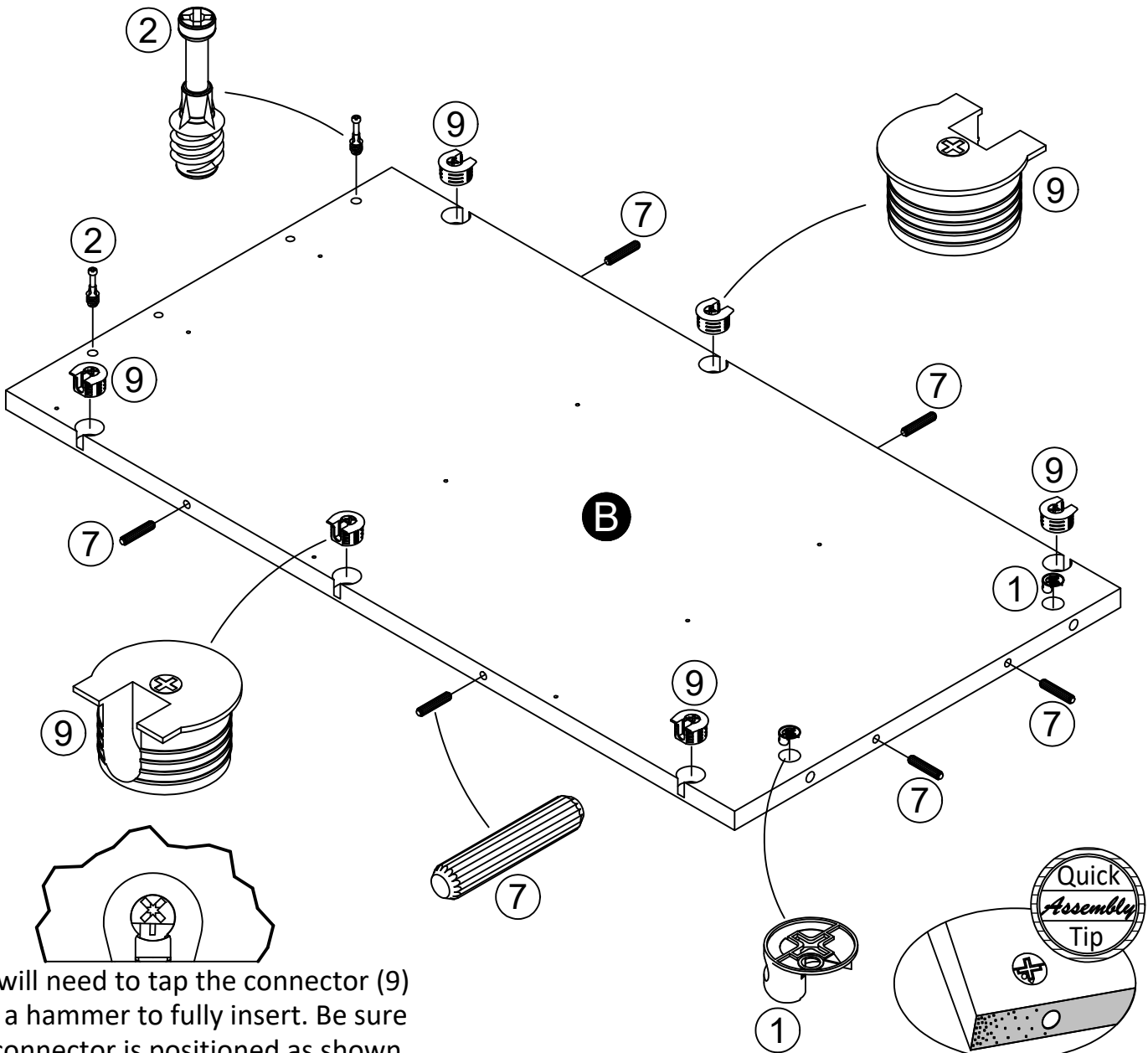
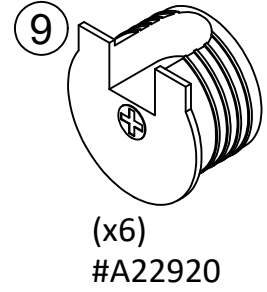
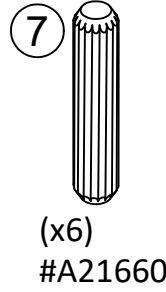
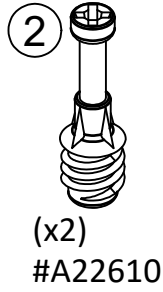
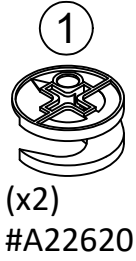
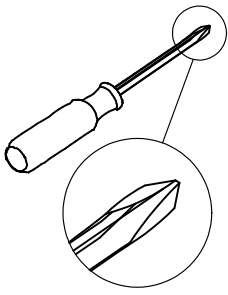
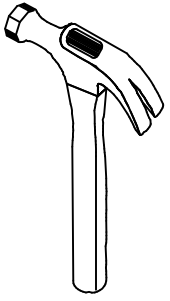

You will need to tap the connector (9) with a hammer to fully insert. Be sure the connector is positioned as shown before tapping into hole.

Quick Assembly Tip  
Proper orientation of CAM LOCK

# STEP 6

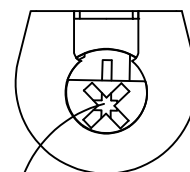
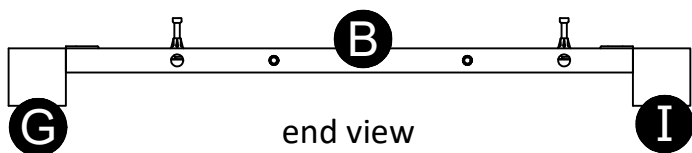
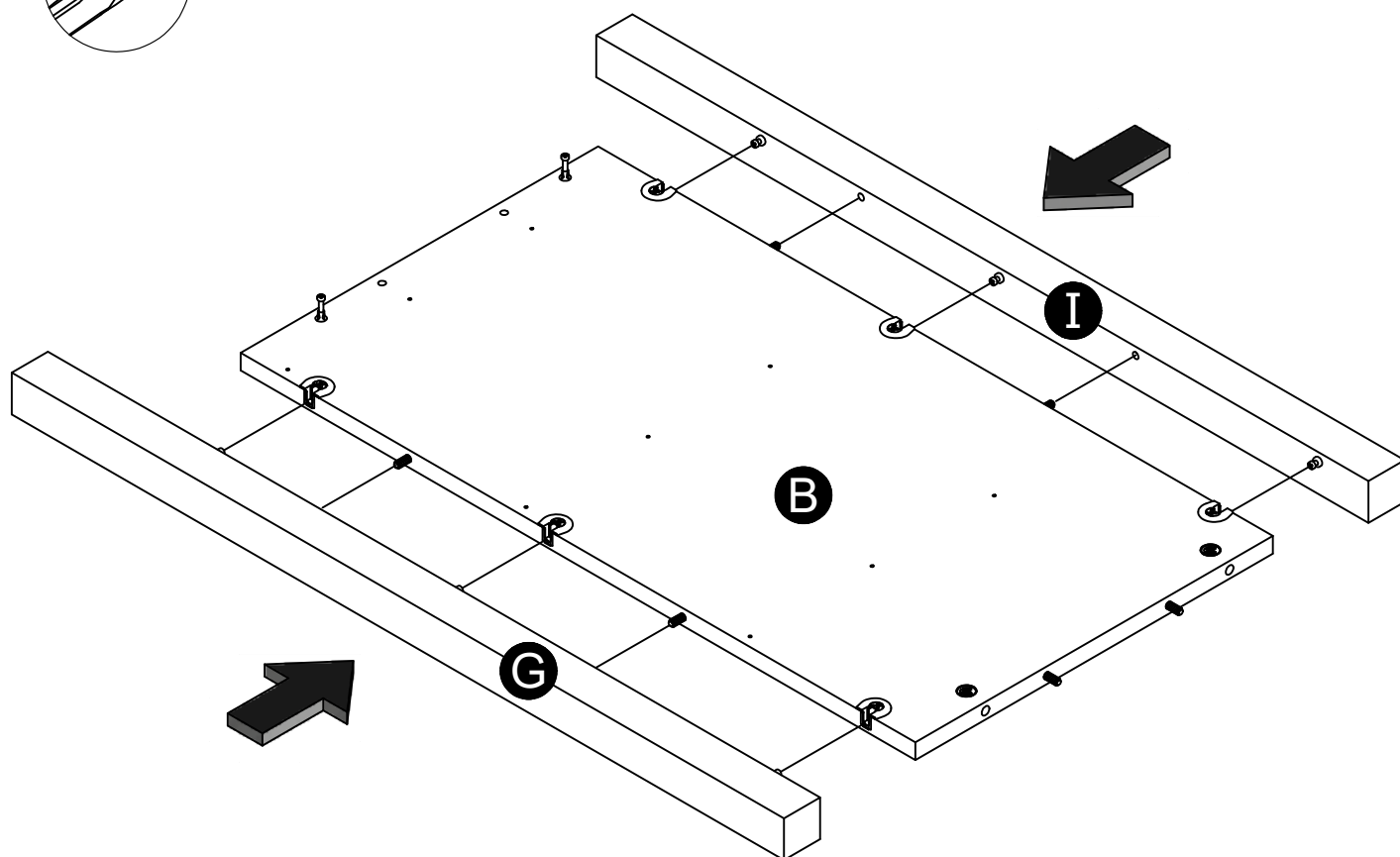
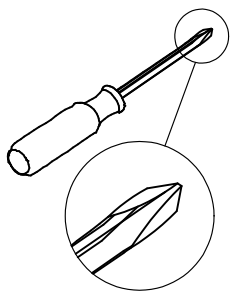

Turn screw clockwise to lock in place.

# STEP 7

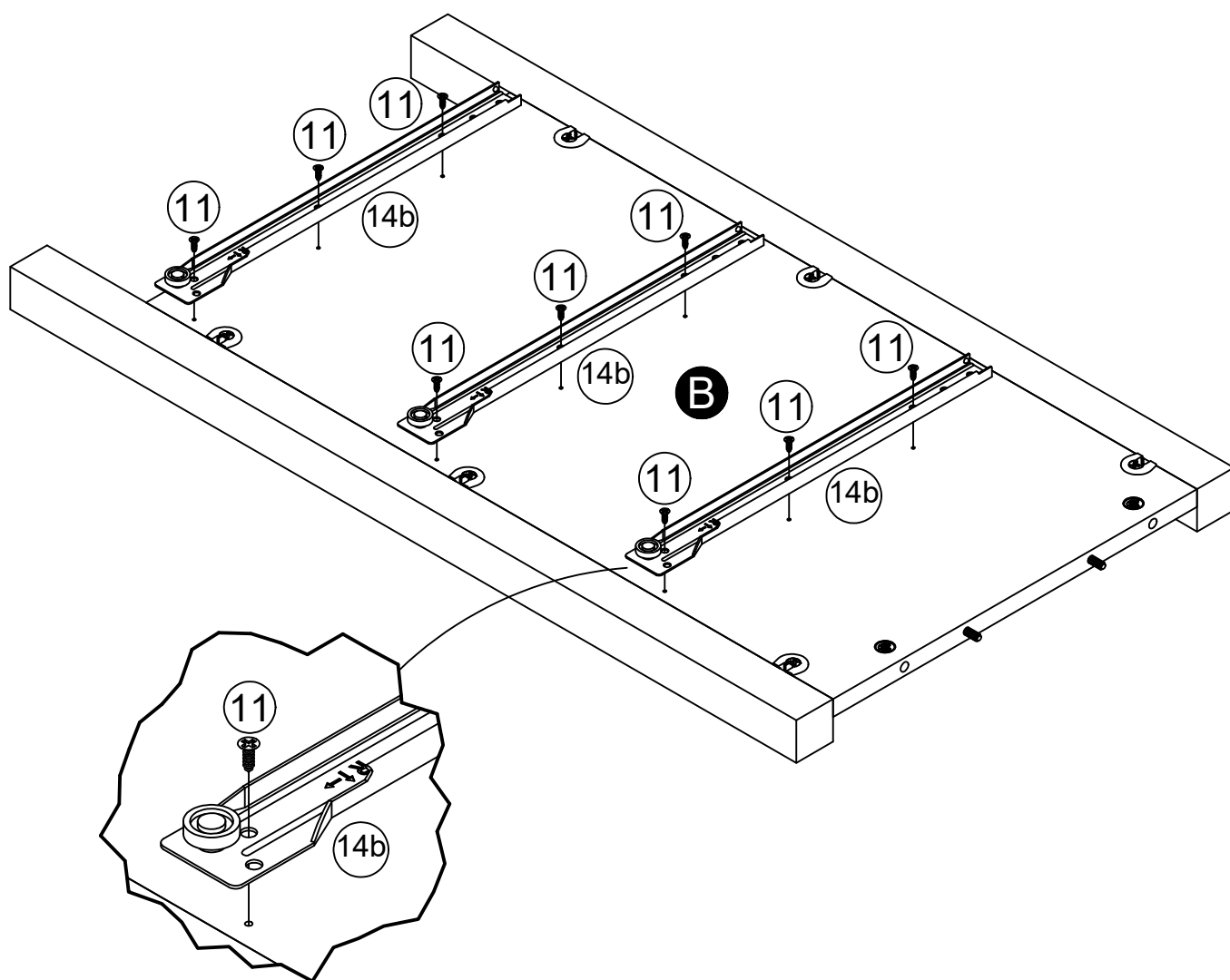
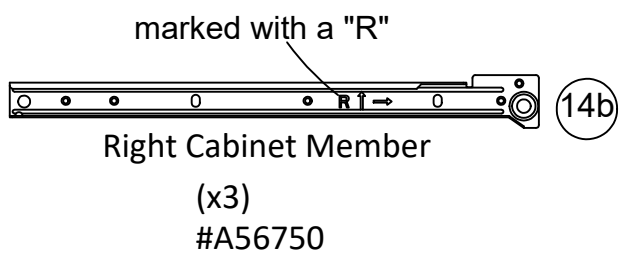
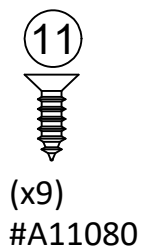
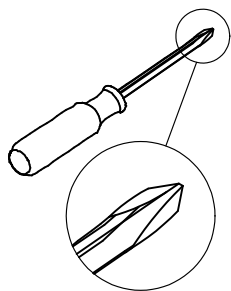

# STEP 8

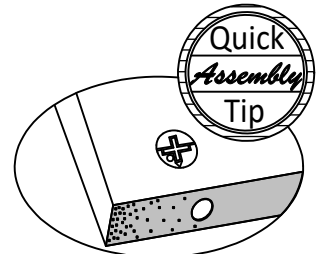
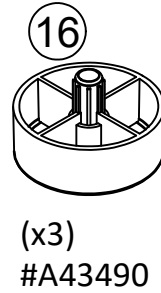
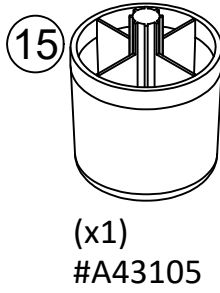
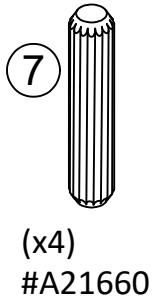
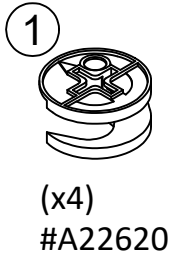

Proper orientation of CAM LOCK

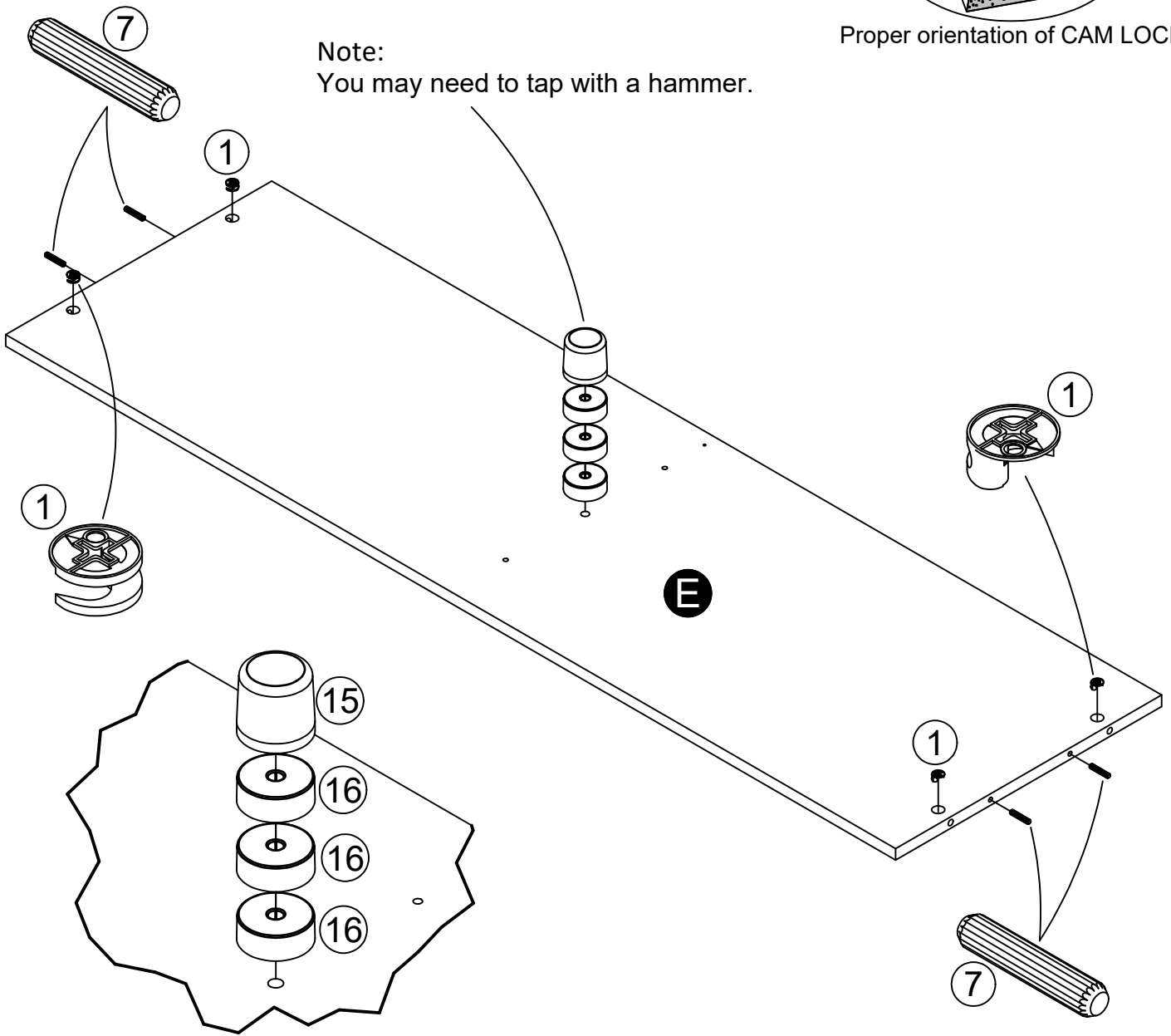



# STEP 9

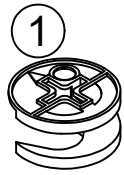
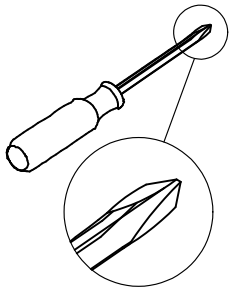

(x2)  
#A22620

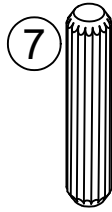

(x2)  
#A21660



(x18)  
#A11080



Left Cabinet Member

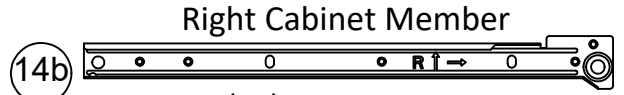

Right Cabinet Member

(x3)  
#A56750  
drawer slide pkg.

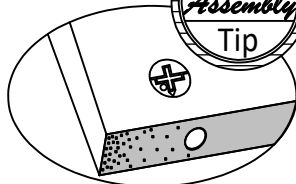

Proper orientation of CAM LOCK

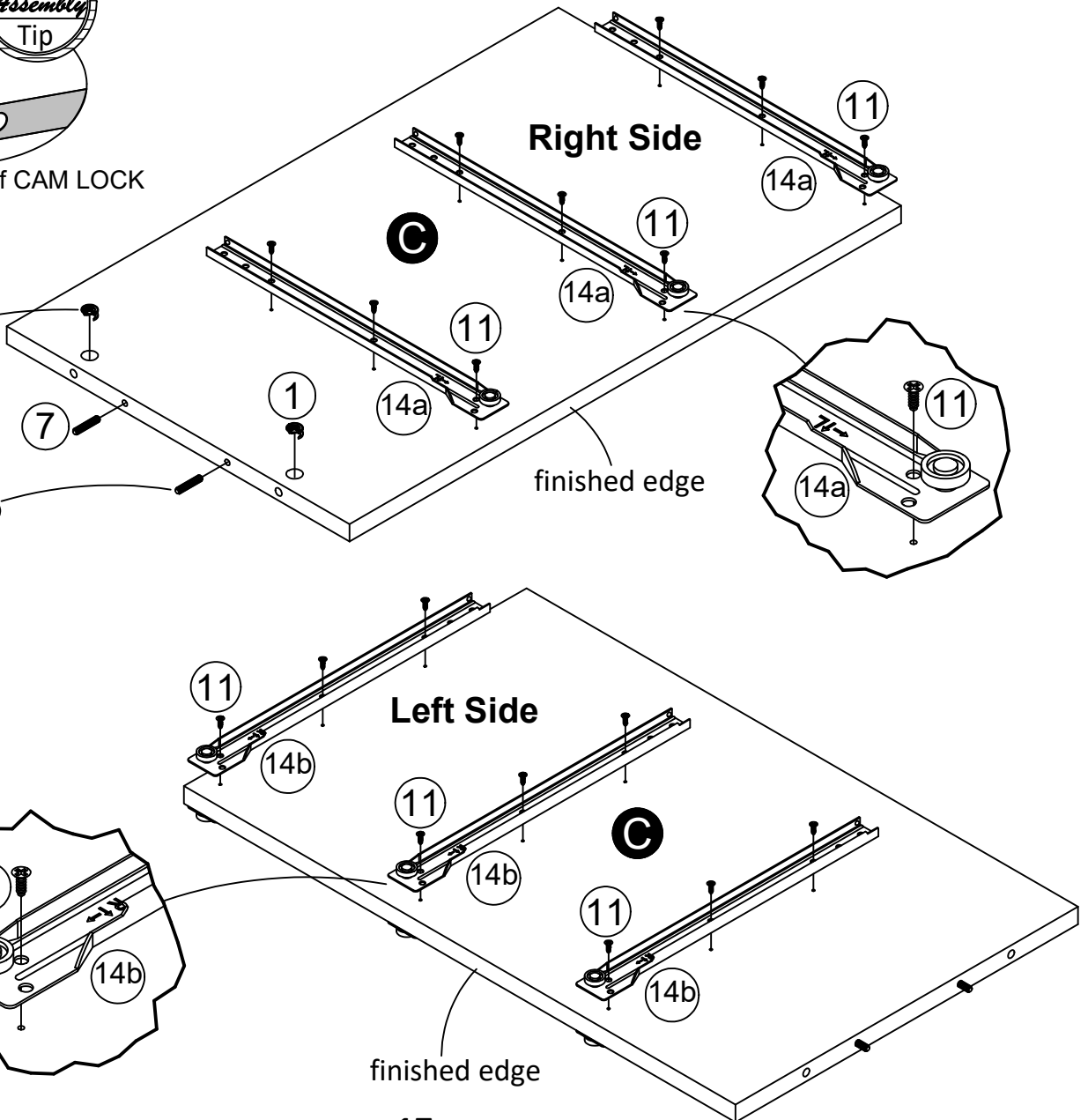
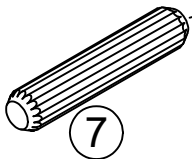

# STEP 10

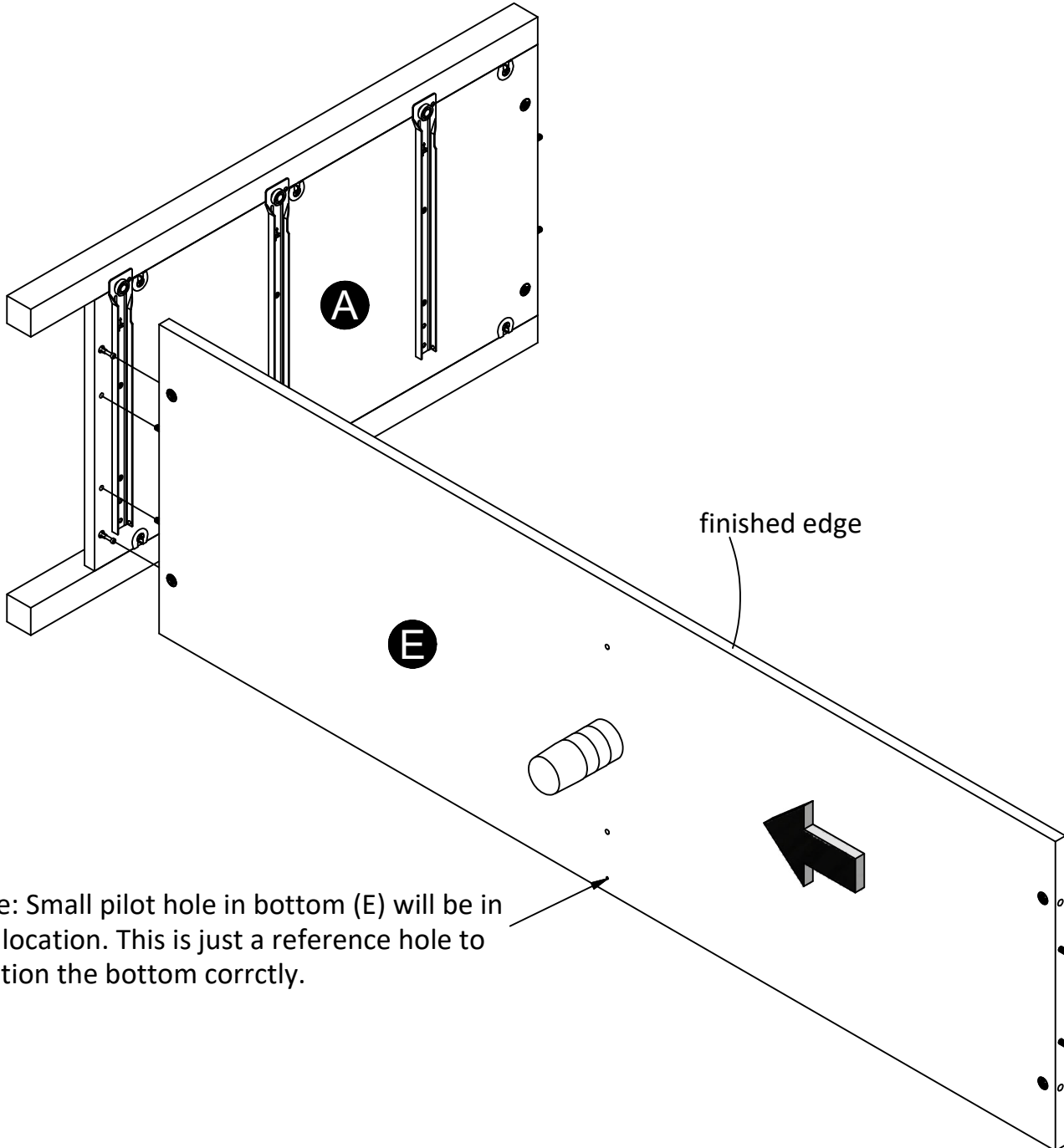
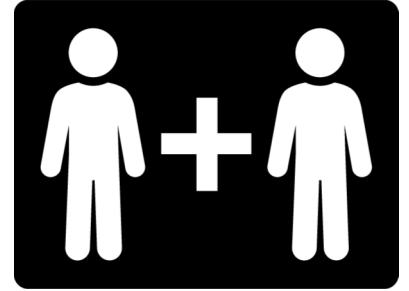
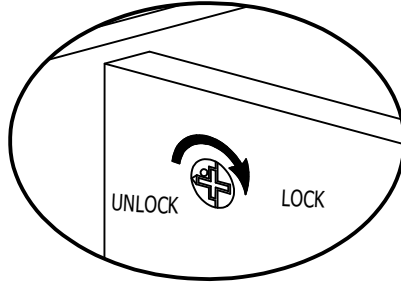
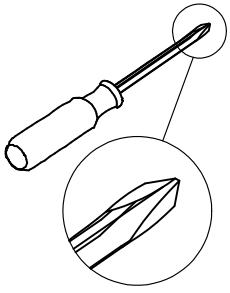

Note: Small pilot hole in bottom (E) will be in this location. This is just a reference hole to position the bottom correctly.

# STEP 11

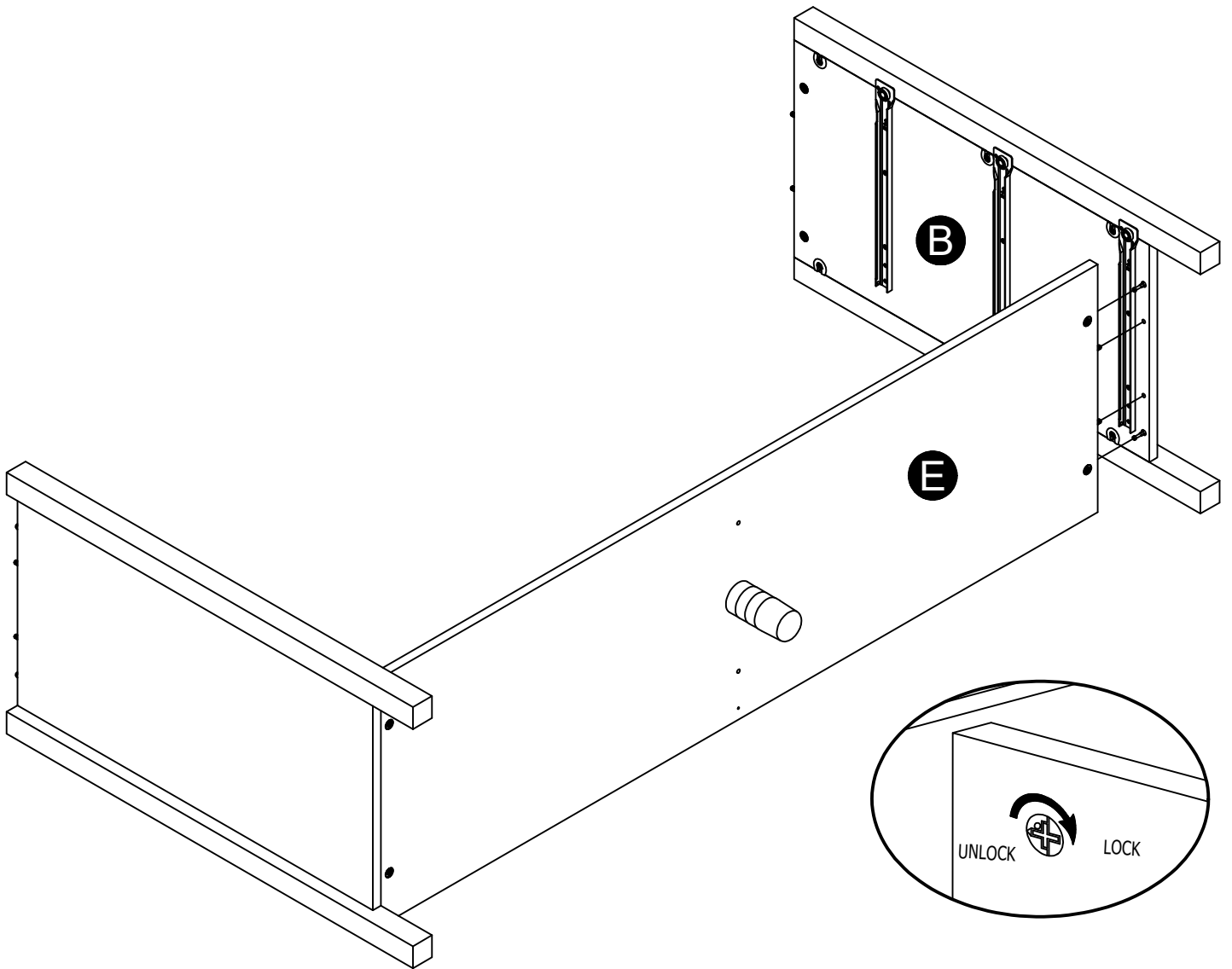
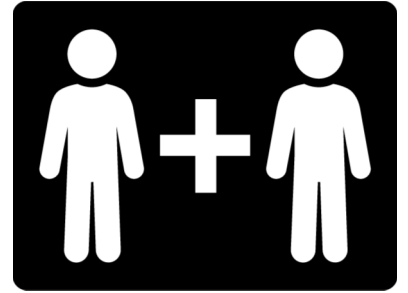
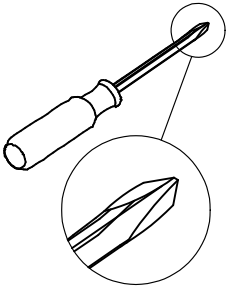

# STEP 12

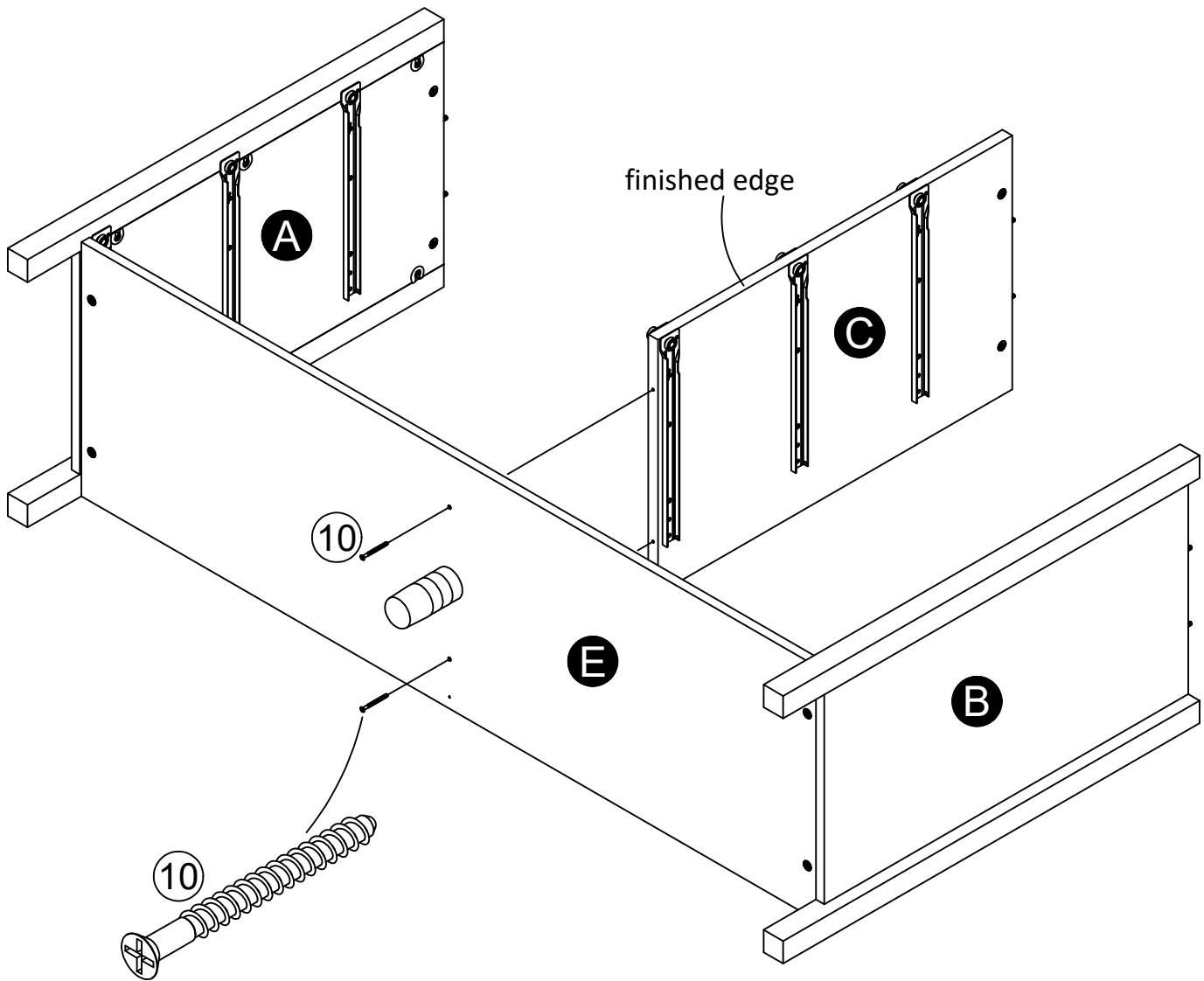
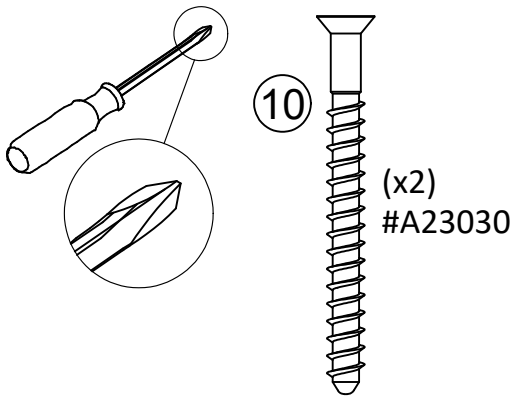

# STEP 13

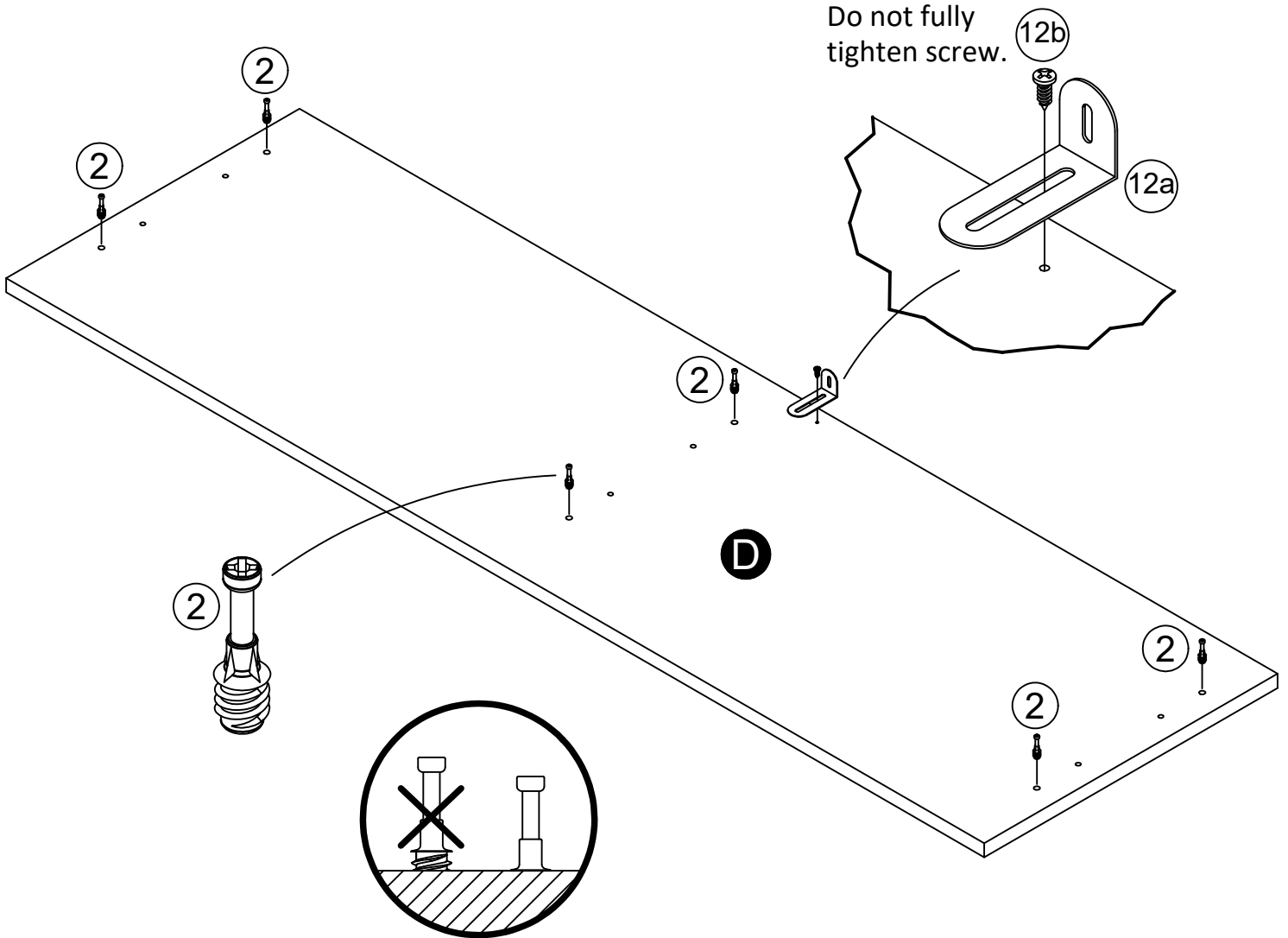
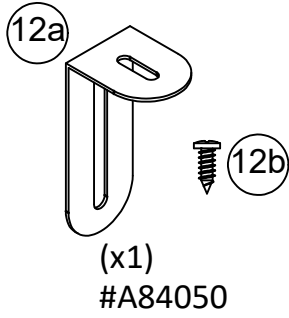
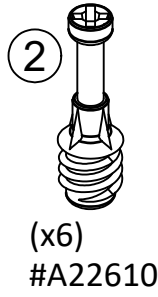
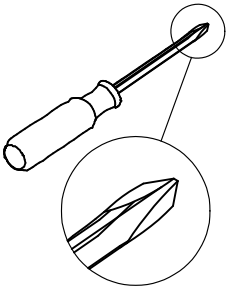

# STEP 14

---

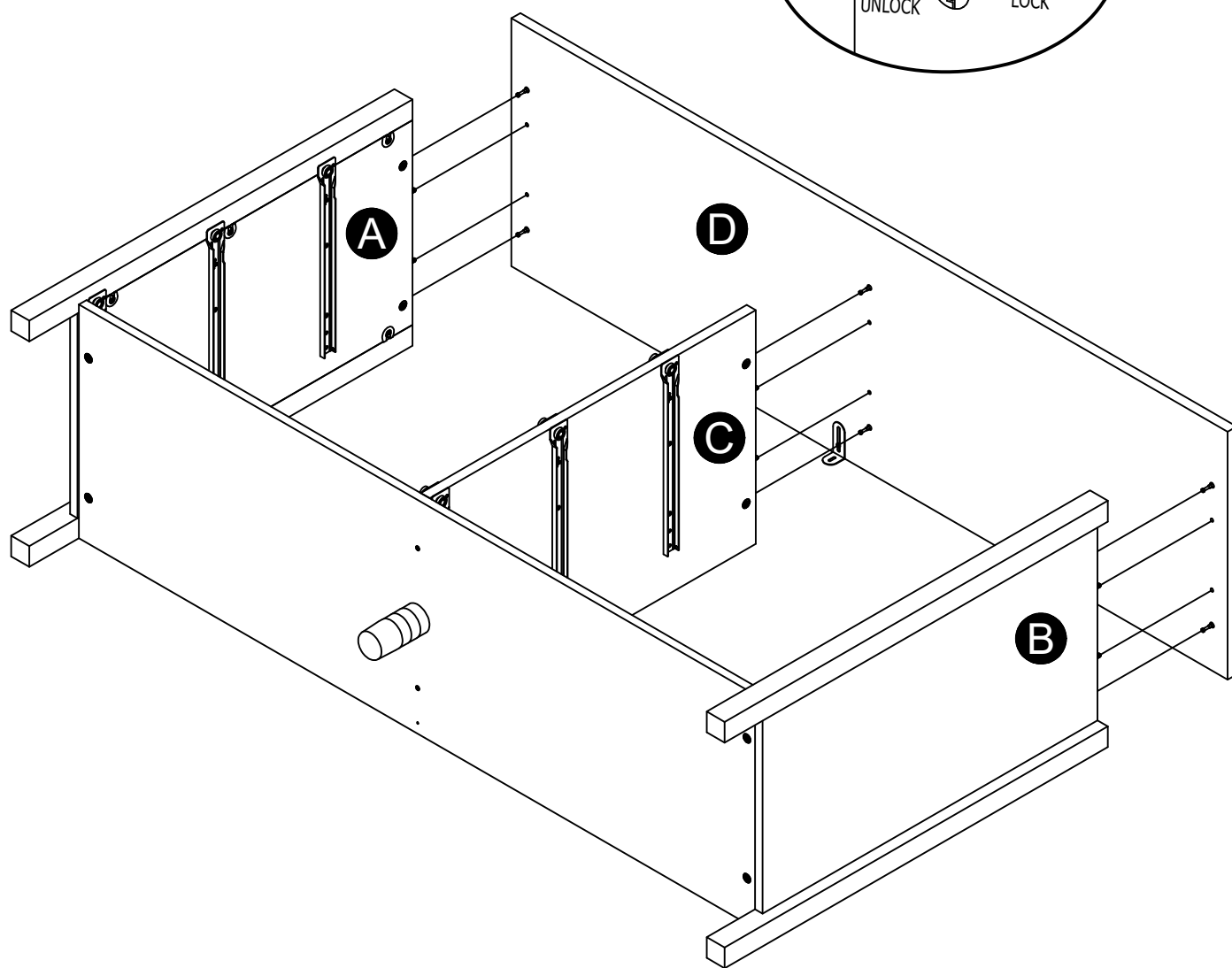
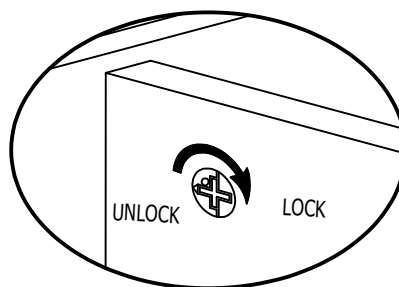
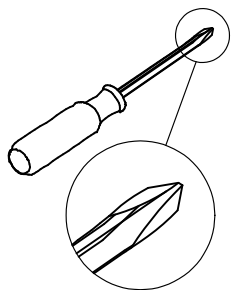

# STEP 15

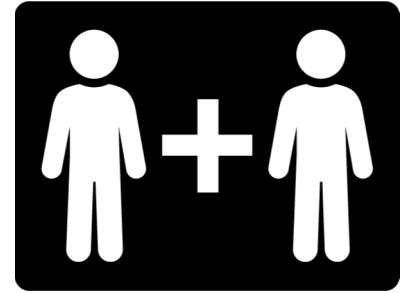
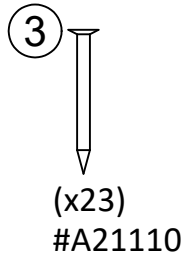
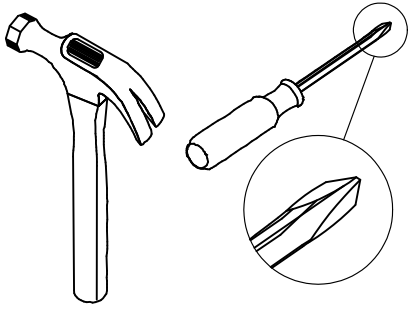

**IMPORTANT!** THE BACK PANEL IS A STRUCTURAL PART OF THIS UNIT AND MUST BE INSTALLED PROPERLY.

With the help of another person, turn the unit over on its front side. Position back panel as shown. Align squarely with outer edges. Attach back panel to rear legs (H&I) with screws (5) but do not tighten. Flush bottom edge of back panel with bottom edge of the bottom and nail straight into back edges of top (D) and bottom (E). Now tighten the screws (5).

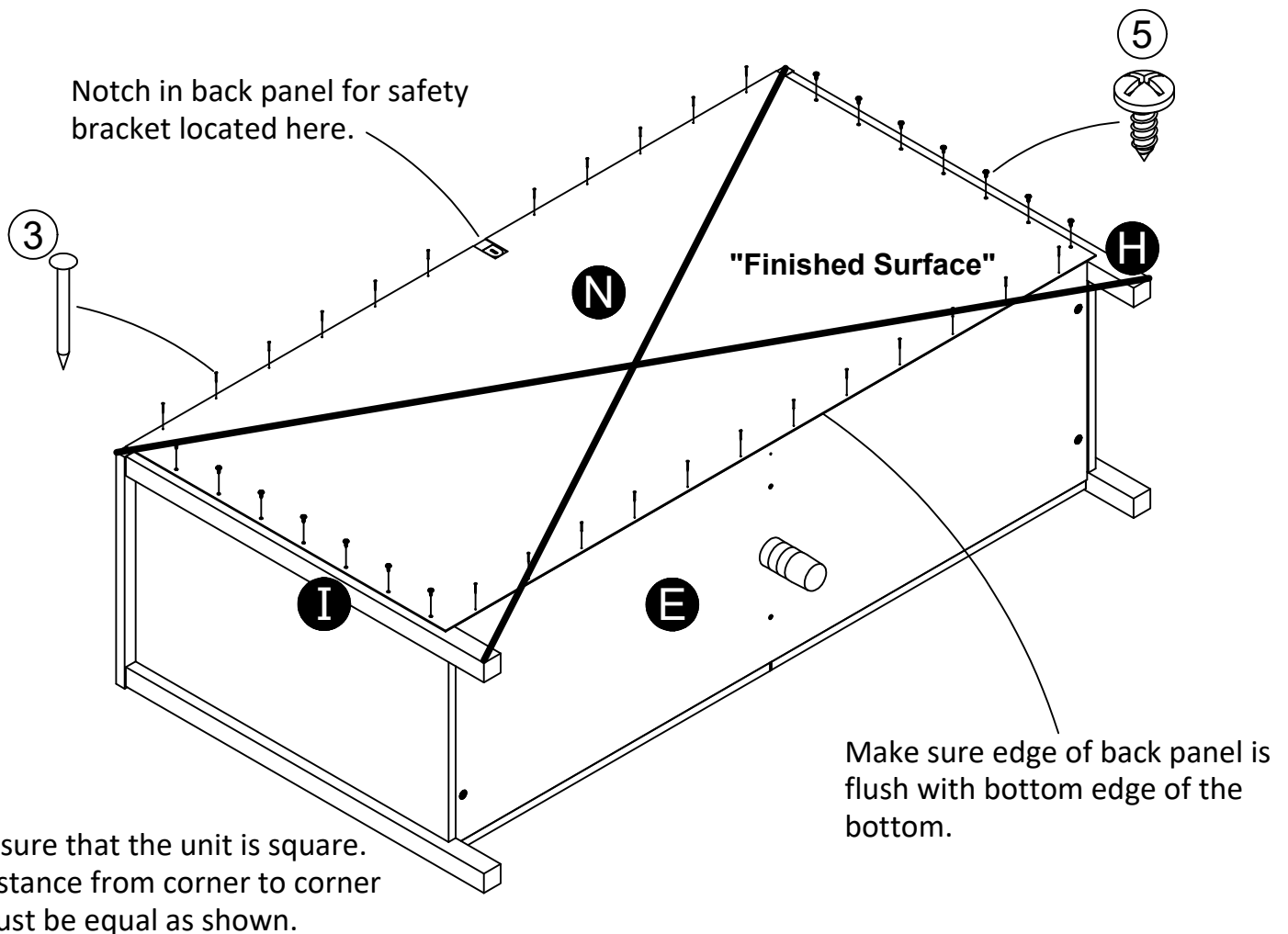

Assure that the unit is square.  
Distance from corner to corner  
must be equal as shown.

# STEP 16

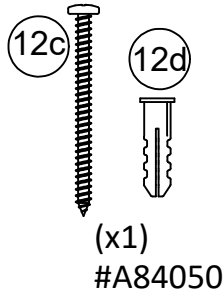
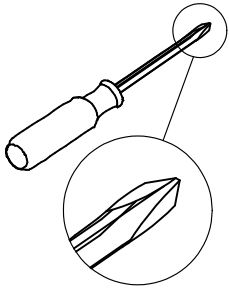

## For Masonry, Concrete, or other wall materials:

Consult your local hardware store for appropriate anchors to securely attach the safety bracket.

**IMPORTANT:** THIS UNIT MUST BE SECURE TO THE WALL TO HELP PREVENT TIPOVER. FOLLOW THESE INSTRUCTIONS TO INSTALL THE ANTI-TIPPING SAFETY BRACKET PROVIDED WITH THIS PRODUCT.

### OPTION 1: Attachment into a wall stud (preferred method)

Using a stud finder, locate a stud in the wall. Place your unit against the wall, with the safety bracket aligned in this location. To make driving the screw easier, you can drill a 1/8" diameter pilot hole (3mm) through the safety bracket into the stud. Drive the screw through the safety bracket into the wall stud. Tighten the screw that was not fully tightened in step 13.

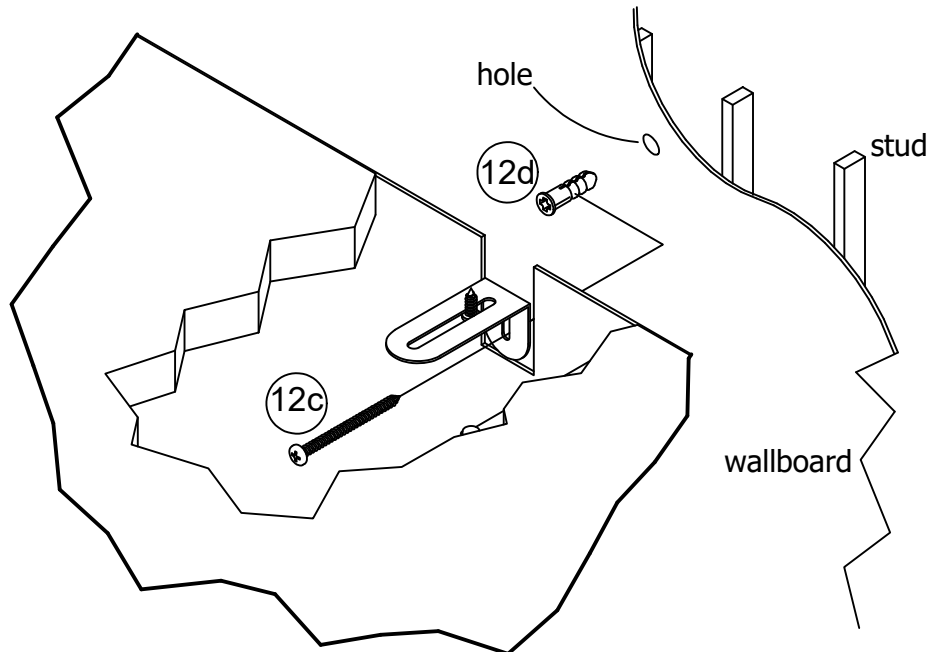

### OPTION 2: Attachment into drywall

Locate your unit where desired against a wall and mark the wall through the safety bracket, then move your unit aside. Drill a 3/16" diameter hole (5mm) into the wallboard. Tap the wall anchor into the hole until it is flush. Move your unit into location and fasten the wall bracket to the wall anchor with the screw. Tighten the screw that was not fully tightened in step 13.

## ⚠ WARNING



Children have died from furniture tip over. To reduce the risk of furniture tip over:

- ALWAYS install tip over restraint provided.
- NEVER put a TV on this product.
- NEVER allow children to stand, climb or hang on drawers, doors, or shelves.
- NEVER open more than one drawer at a time.
- Place heaviest items in the lowest drawers.





# STEP 17

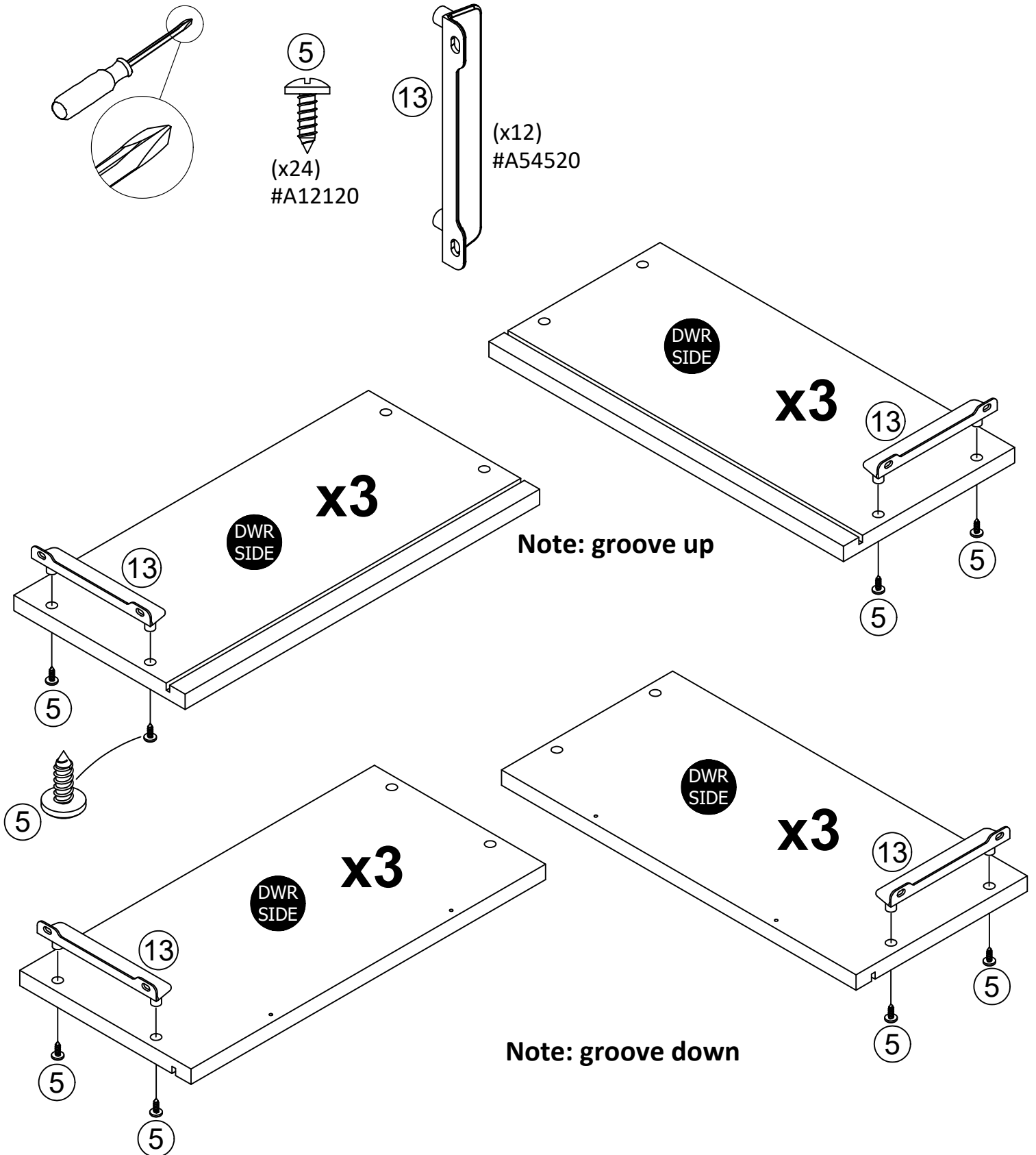

# STEP 18

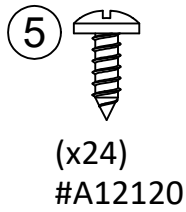
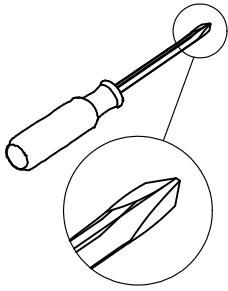

Note: This view shows the set-up for the three left side drawers (drawer fronts J and L). For the three right side drawers (drawer fronts K and M), it's the same process but with the outside drawer bracket on opposite side.

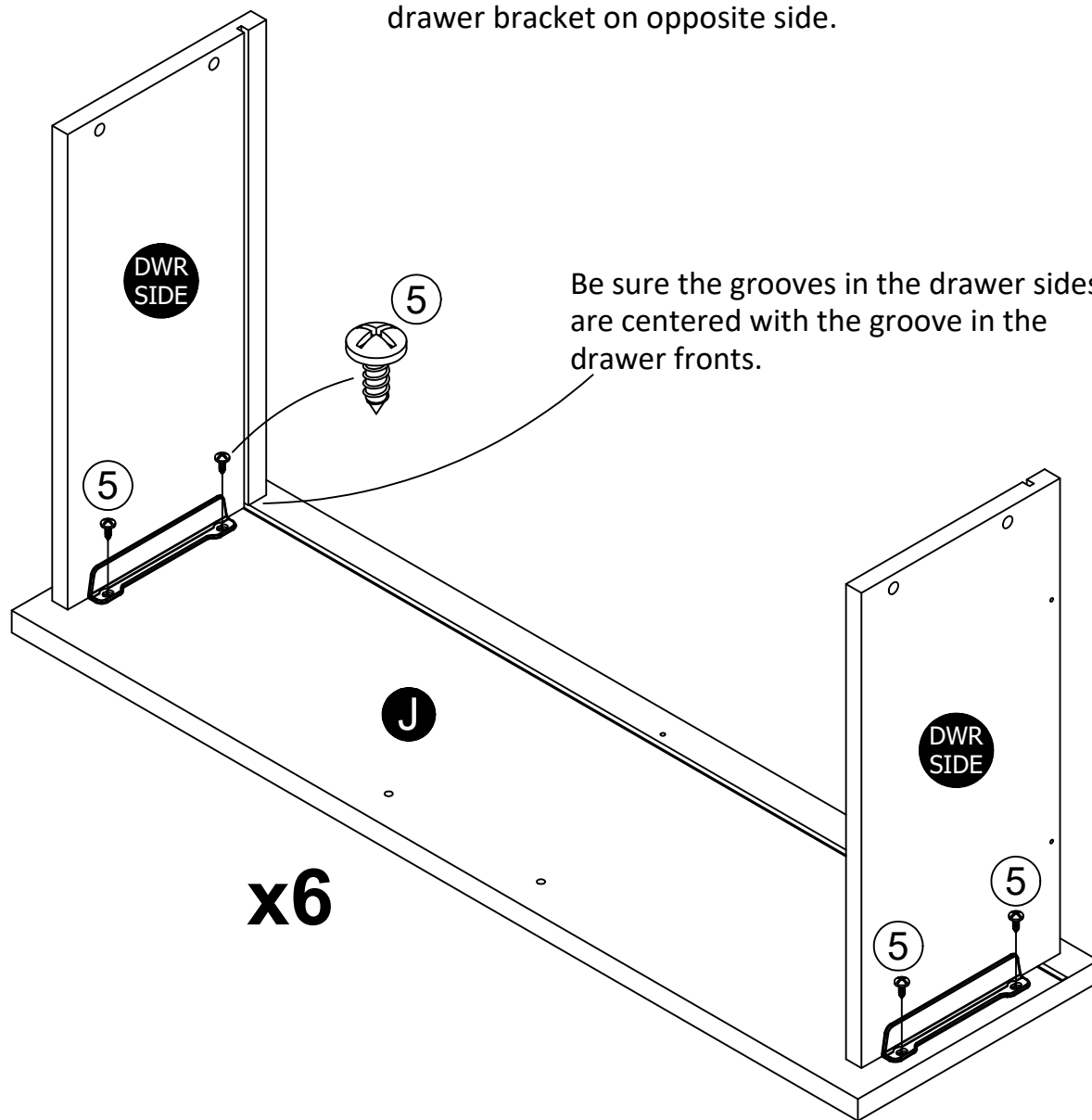

# STEP 19

---

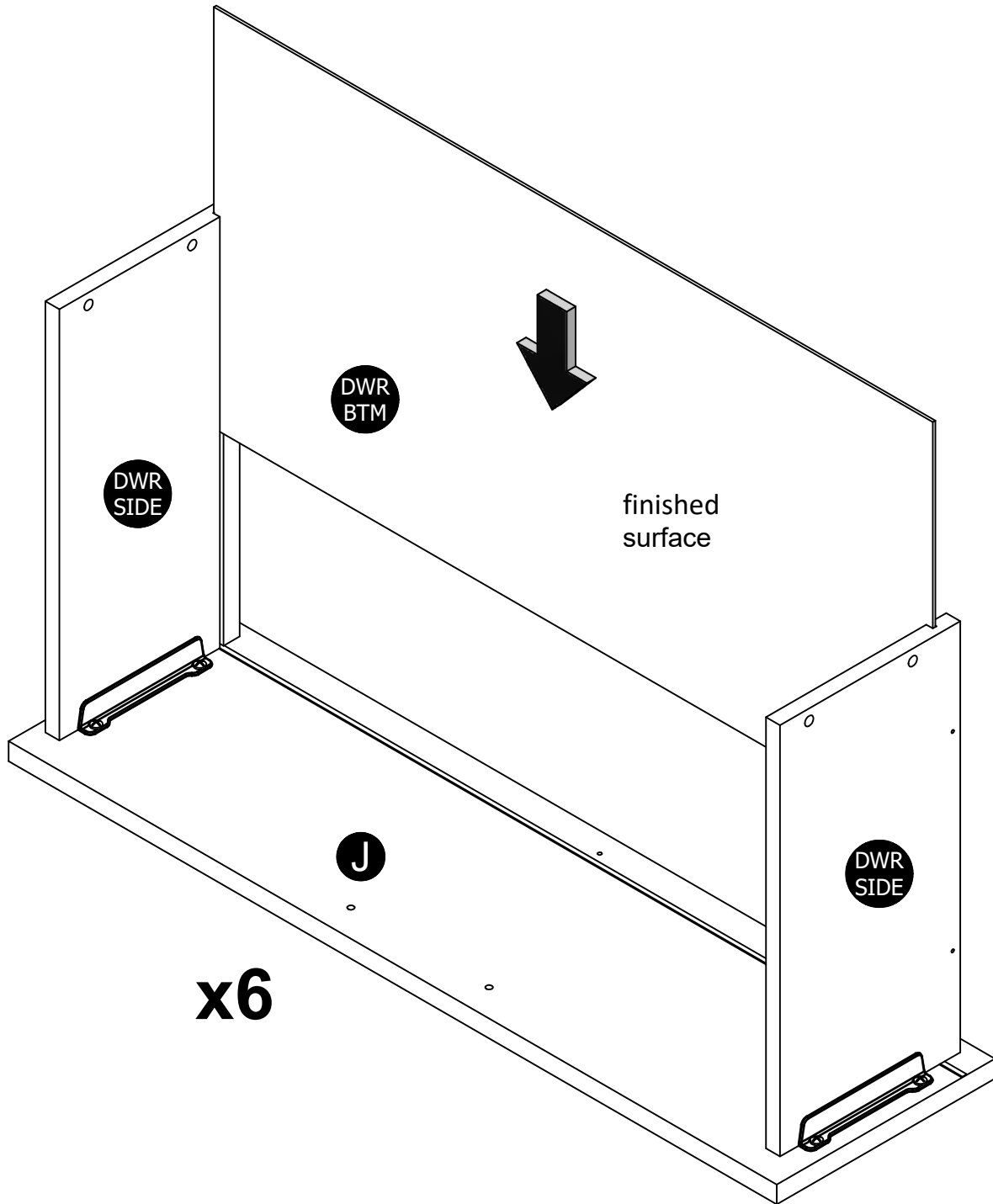

# STEP 20

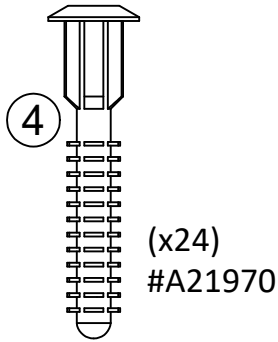
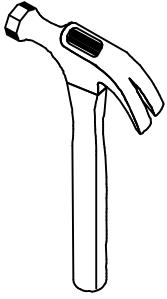

Note: You will need to tap the drive fasteners (4) with a hammer to securely fasten.

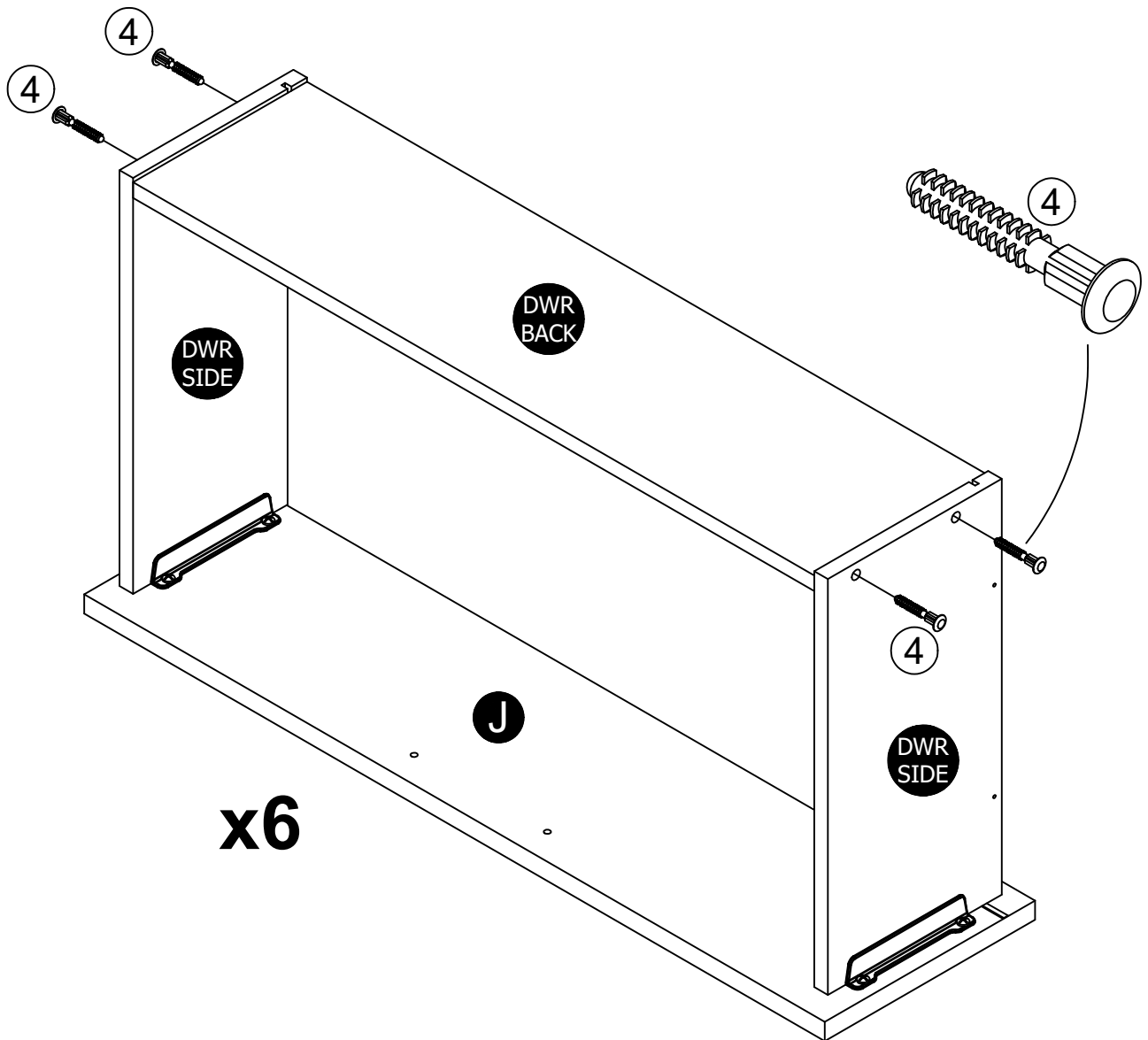

# STEP 21

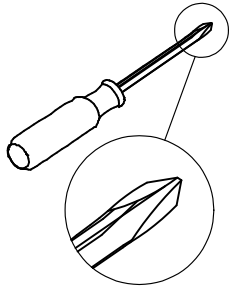

5  
(x12)  
#A12120

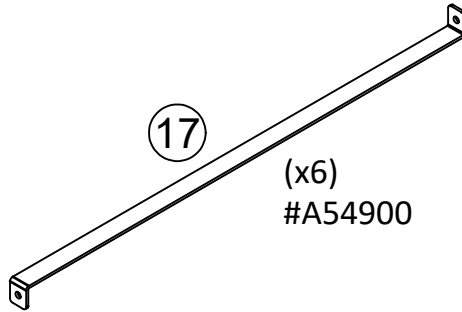

(x6)  
#A54900

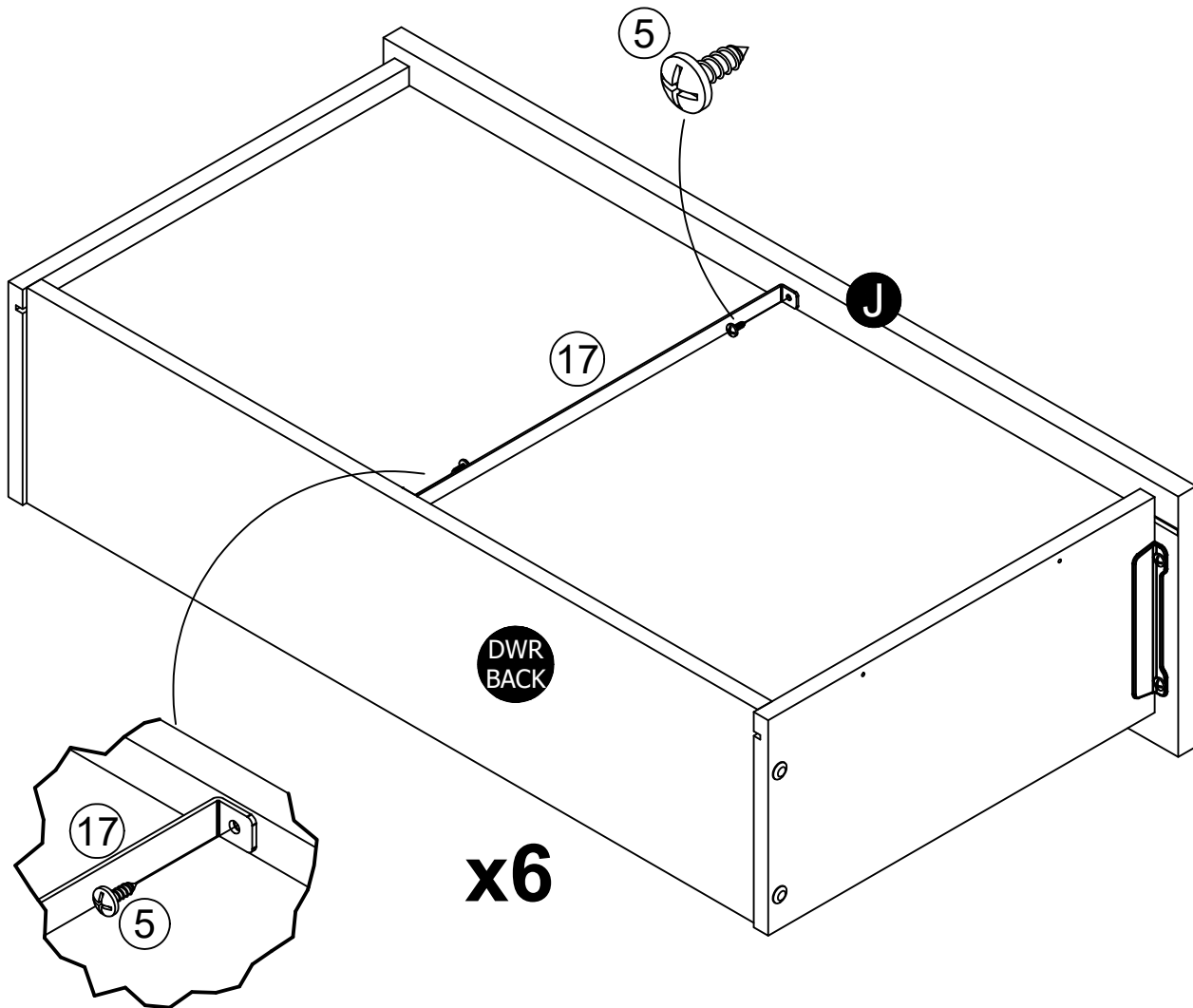

# STEP 22

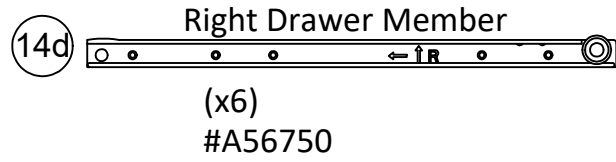
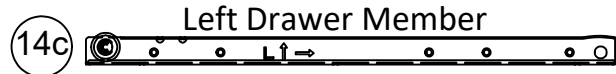
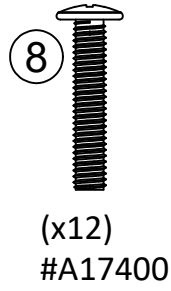
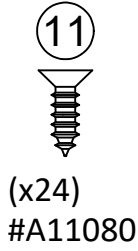
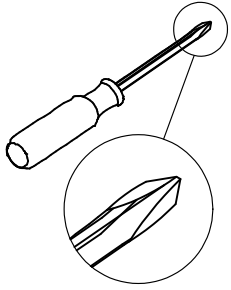

Attach the slides first and then the handles.

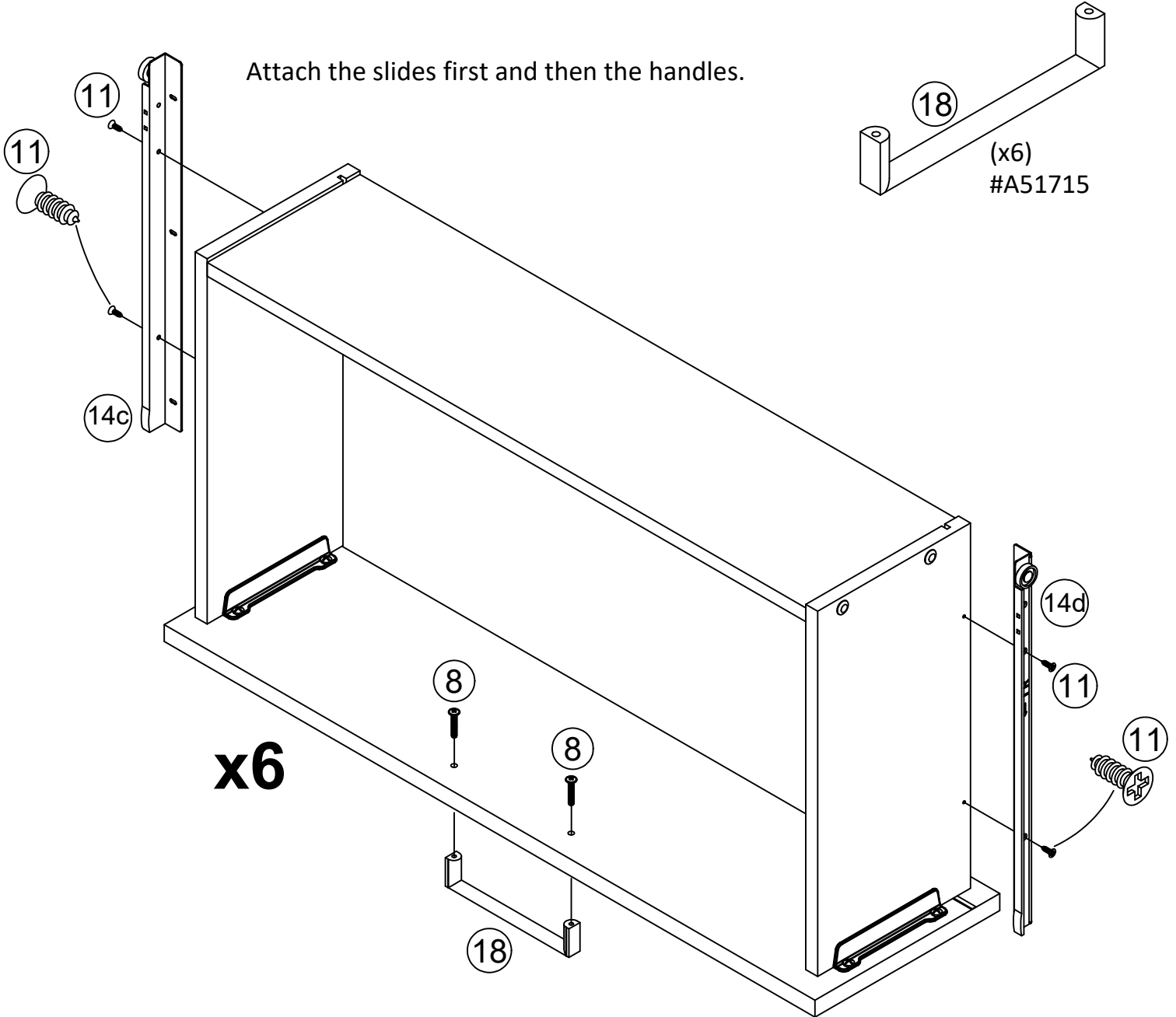

# STEP 23

Note: The drawer bracket holes are slotted. Drawer fronts can be adjusted by loosening screws, making needed adjustments and retightening screws.

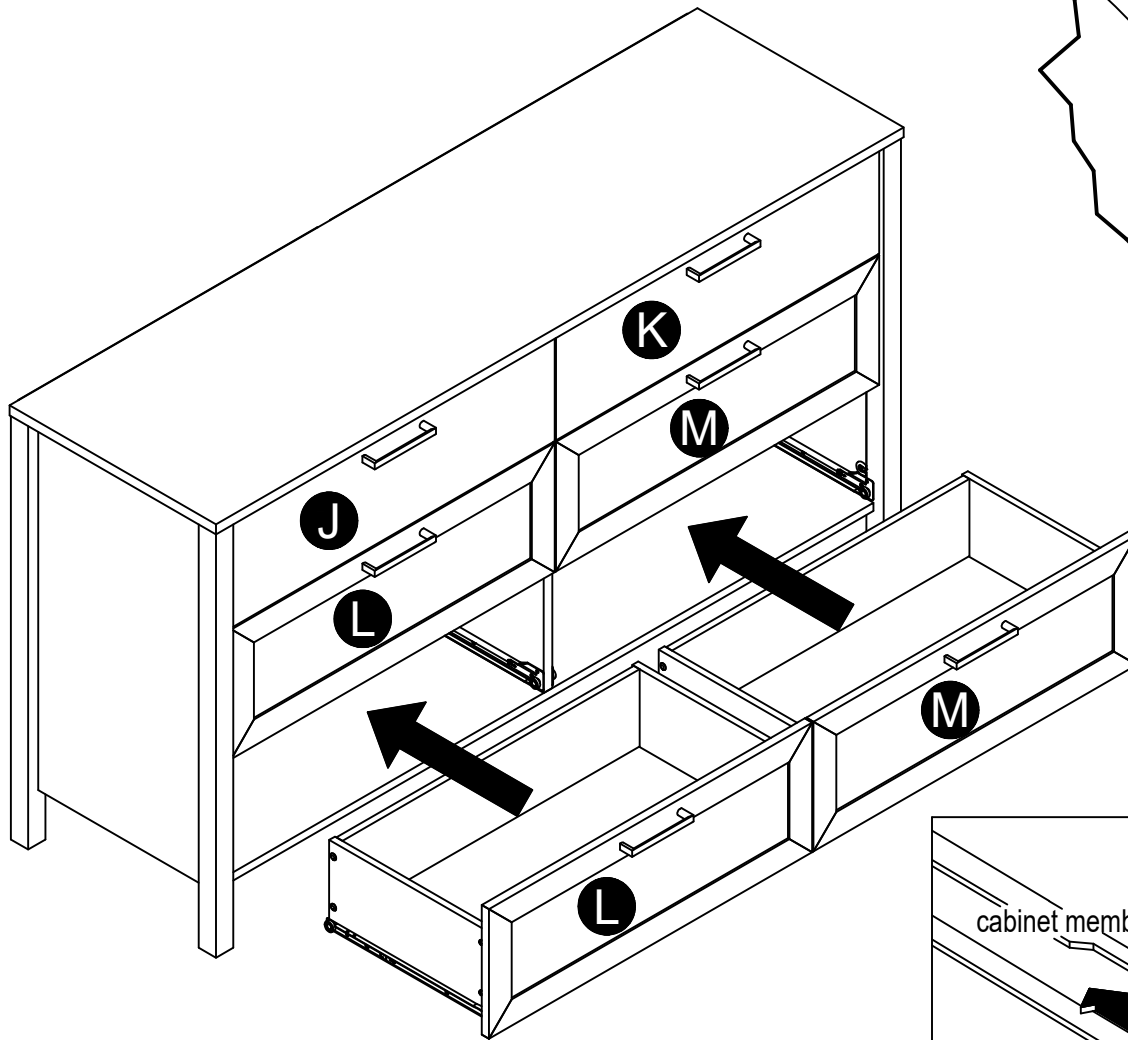

Insert the six drawers. Note that the drawer bracket for the three left drawers are outside to the middle and the drawer bracket for the three right drawers are outside to the middle.

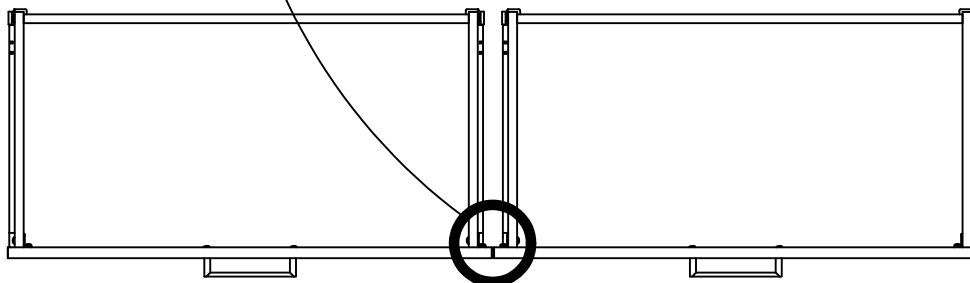
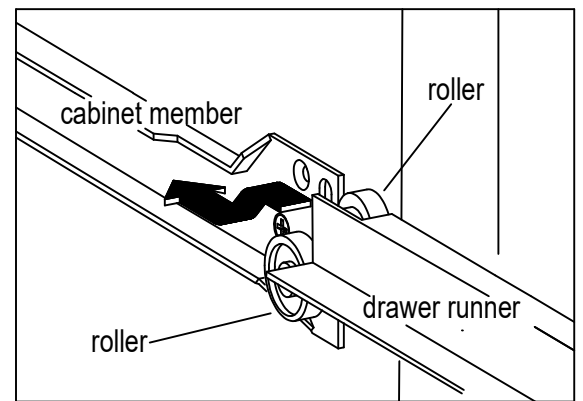

# Maximum Loads

---

This unit has been designed to support the maximum loads shown. Exceeding these load limits could cause sagging, instability, product collapse, and/or serious injury.

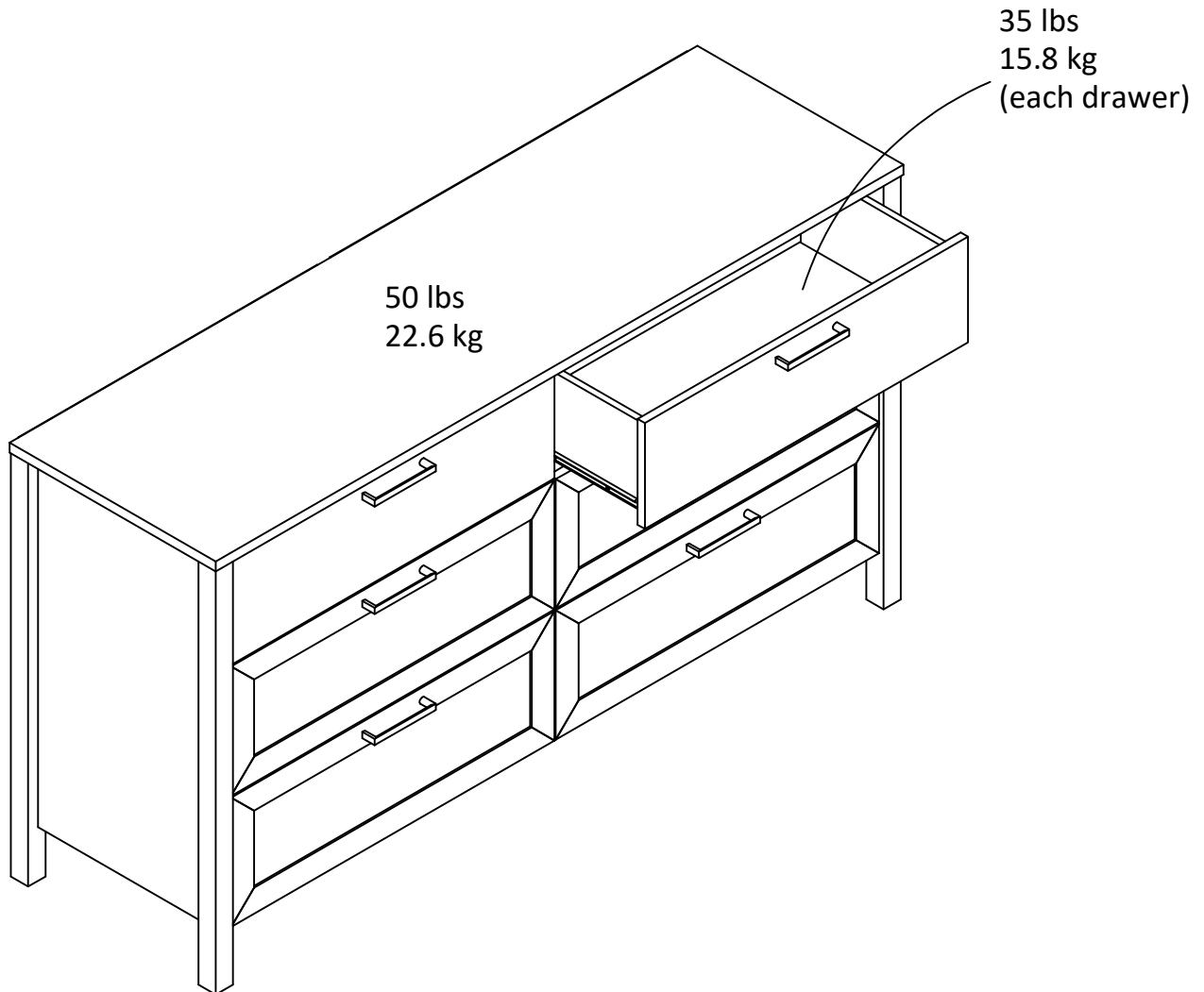

**Warning: Risk of injury to persons - do not place a television on this furniture. This furniture is not approved for use with a television.**

---

## Certificate of Conformity

1. This certificate applies to the Dorel Home Furnishings, Inc. product identified by this instruction manual.
2. This certificate applies to compliance of this product with the CPSC Ban on Lead-Containing Paint (16 CFR 1303).
3. This product is distributed by: Dorel Home Furnishings, Inc.  
410 East First Street South  
Wright City, MO 63390  
636-745-3351
4. Site of Manufacture: Tiffin OH
5. See front page of instruction manual for date of manufacture.



---

## Register your product to receive the following:



- \* New trend details - sneak peek on what's new
- \* Surveys - have a voice within our community
- \* Exclusive deals and discount codes
- \* Quick and easy replacement part service

To register your product, visit [ameriwoodhome.com](http://ameriwoodhome.com)

## *5 Star Rating*



Visit your local retailer's website, rate your purchased product and leave us some feedback!

We would like to extend a big "Thank You" to all of our customers for taking the time to assemble this Ameriwood Home product, and to give us your valuable feedback.

*Thank  
You!*

# Español

---

## Cubierta Delantera

Este libro de instrucciones contiene información **IMPORTANTE** de seguridad. Por favor lea y manténgalo para referencia en el futuro.

**No Regrese este producto!** Comuníquese con nuestro amistoso equipo de servicio al cliente para obtener ayuda.

Llámenos al: 1-800-489-3351 (Gratis)

**Visitar:** [www.ameriwoodhome.com](http://www.ameriwoodhome.com)

## PRECAUCION

Este mueble puede volcarse y causar graves heridas y/o muerte.

Anclar el mueble a un poste de madera en la pared (si esto se requiere).

No Permita que los niños monten el mueble.

Mantenga los artículos más pesados en los cajones de abajo.

## Consejos Útiles (página 2)

- Abra su artículo en el área donde usted planea utilizarlo para evitar levantar y moverlo menos
- Identificar, ordenar y contar las piezas antes de intentar ensamblar
- Las clavijas de compresión se golpean con un martillo
- Las diapositivas están marcadas con una R (derecha) y L (izquierda) para la colocación correcta
- Asegúrese de que siempre este el punto localizado en la parte superior de bloqueador de leva este volteado hacia borde exterior
- Utilizar todos los clavos para el panel de atrás y distribuirlos por igual
- El panel de atrás debe utilizarse para asegurarse de que la unidad quede fija y firme
- No use químicos fuertes ni limpiadores abrasivos en este artículo
- Nunca empuje, tire ni arrastre los muebles

## Antes de Que Empieces (página 3)

- Lea cuidadosamente cada paso y siga el orden correcto

- Separar y contar todas sus piezas y hardware

- Dése suficiente espacio para el proceso de ensamble

- Tenga las siguientes herramientas: destornillador de cabeza plana, #2 cabeza Phillips

Destornillador y martillo

- Precaución: Si usa un taladro electrónico o un destornillador eléctrico para atornillar, por favor asegúrese que deje de atornillar cuando el tornillo este apretado. Fallar hacer esto puede causar barrer el tornillo.

## Sistema de fijar el bloqueo de leva (página 3)

Este sistema de fijar el bloqueo de leva será usado en todo el proceso ensamble.

## Página 4

Por favor, tenga en cuenta que:

Es posible que deba golpear ligeramente las clavijas de madera para insertarlas en los agujeros durante el proceso de ensamblaje.

# Español

---

## **Página 10 de 13**

Golpee el conector (9) con un martillo para introducirlo por completo. Antes de introducir el conector en el agujero, asegúrese de que esté colocado tal como se muestra.

## **Página 21**

No apriete los tornillos por completo.

## **Página 23**

**¡IMPORTANTE! EL PANEL POSTERIOR ES UNA PARTE ESTRUCTURAL DE ESTA UNIDAD Y DEBE INSTALARSE DE LA MANERA ADECUADA.**

Con la ayuda de otra persona, voltee la unidad sobre su cara frontal. Coloque el panel trasero como se muestra. Alinee de forma recta con los bordes exteriores. Fije las patas traseras (H&I) al panel trasero con tornillos (5), pero no los apriete. Junte el borde inferior del panel posterior con el borde inferior del fondo y clávelo directamente en los bordes posteriores de las partes superior (C) e inferior (D). Luego, apriete los tornillos (5).

Compruebe que la unidad esté bien alineada.

La distancia de esquina a esquina debe ser la que se muestra.

Asegúrese que el panel posterior esté alineado con el borde inferior del fondo.

## **Página 24**

### **Para mampostería, hormigón o muros de otros materiales:**

Consulte con su ferretería local sobre los anclajes adecuados para sujetar de forma segura el soporte de seguridad.

**IMPORTANTE:** ESTA UNIDAD SE DEBE FIJAR A LA PARED PARA EVITAR QUE SE VUELQUE HACIA ADELANTE. SIGA ESTAS INSTRUCCIONES PARA INSTALAR EL SOPORTE DE SEGURIDAD ANTIVUELCO QUE SE SUMINISTRA CON ESTE PRODUCTO.

### **OPCIÓN 1: Fijación en un montante de pared (método recomendado)**

Localice un montante usando un detector de clavos. Coloque la unidad contra la pared con el soporte de seguridad alineado. Con el fin de facilitar la introducción del tornillo, haga un agujero de taladro de 1/8 de pulgada (3 mm) en el montante a través del soporte de seguridad. Atornille a través del soporte de seguridad. Apriete el tornillo que no había apretado por completo en el paso 11.

### **OPCIÓN 2: Fijación en un panel de yeso**

Coloque la unidad en el lugar deseado, haga una marca en la pared a través del soporte de seguridad y retire la unidad. Haga un agujero de taladro de 3/16 de pulgada (5 mm) de diámetro en el panel de la pared. Empuje el anclaje de pared en el agujero hasta que esté totalmente introducido. Coloque la unidad en su lugar y atornille el soporte en el anclaje de pared. Apriete el tornillo que no había apretado por completo en el paso 11.

# Español

---

## **Página 26**

Nota: Esta vista muestra el montaje de los tres cajones del lado izquierdo (frontales de cajón J y L). Para montar los tres cajones del lado derecho (frontales de cajón K y M), se realiza el mismo proceso, pero con el soporte del cajón exterior en el lado opuesto.

Asegúrese de que las ranuras en los lados de los cajones estén centradas con las ranuras de los frontales.

## **Página 28**

Nota: Golpee las sujeciones de la unidad (4) con un martillo para que retengan de forma segura.

## **Página 30**

Primero coloque las correderas y luego las manillas.

## **Página 31**

Nota: Los orificios del soporte de los cajones tienen ranuras. Los frontales de los cajones se pueden ajustar aflojando los tornillos, moviéndolos según sea necesario y volviendo a apretar los tornillos.

Introduzca los seis cajones. Tenga en cuenta que tanto el soporte de los tres cajones de la izquierda como el de los tres cajones de la derecha están en la parte de afuera hacia el medio.

## **Página 32**

### **CARGA MAXIMA**

Esta unidad ha sido diseñada para soportar la carga máxima anotada. El exceder estos límites puede causar inestabilidad, colapsarse y/o causar serias lesiones.

**ADVERTENCIA:** Riesgo de lesiones a las personas - no coloque un televisor sobre muebles. Este mueble no está aprobado para su uso con un televisor.

## **Página 33**

Registre su producto para recibir lo siguiente:

- \* Detalles de nuevas tendencias - Vistazo a lo nuevo
- \* Encuestas - aloc su voz entre su comunidad
- \* Códigos de ofertas y descuentos exclusivos
- \* Fácil y rápido servicio de partes de remplace

Para registrar su producto, visite [ameriwoodhome.com](http://ameriwoodhome.com)

Clasificación de 5 estrellas

Visite el sitio web de su tienda local, califique su comprado y denos sus comentarios!

Nos gustaría enviar un gran "Agradecimiento" a todos nuestros clientes por tomarse el tiempo de ensamblar este producto de Ameriwood Home, y por darnos sus valiosos comentarios.

Gracias

# Français

---

## Couverture Avant

CE LIVRET D'INSTRUCTION CONTIENT DES INFORMATIONS **IMPORTANTES** SUR LA SÉCURITÉ. VEUILLEZ LIRE ET GARDER POUR UNE RÉFÉRENCE FUTURE

**Ne retournez pas ce produit!** Contactez notre équipe de service à la clientèle amicale d'abord pour obtenir de l'aide.

**Appelez-nous:** 1-800-489-3351 (sans frais)

**Visitez:** [www.ameriwoodhome.com](http://www.ameriwoodhome.com)

## ATTENTION

Le meuble peut basculer et causer des blessures graves ou la mort.

Ancrer le meuble à une planche murale dans le mur (si indiqué).

Ne laissez pas les enfants grimper sur le meuble.

Placez les articles lourds sur les étagères ou dans les tiroirs inférieurs.

## Astuces Utiles (page 2)

-Ouvrez votre article dans la zone que vous prévoyez de le garder pour moins de levage lourd

-Identifier, trier et compter les pièces avant d'essayer d'assembler

-Les goujons de compression sont taraudés avec un Marteau

-Les glissières sont marquées d'un R (droit) et d'un L (gauche) pour un bon placement

-Assurez-vous toujours de faire face la pointe situé sur le haut de la Serrure de Came vers le bord extérieur

-Utiliser tous les clous fournis pour le panneau arrière et les répartir également

-Le panneau arrière doit être utilisé pour vous assurer que votre appareil est robuste

-N'utilisez pas de produits chimiques agressifs ou de nettoyeurs abrasifs sur cet appareil

-Ne jamais pousser, tirer, ou faire glisser votre meuble

## Avant de Commencer (page 3)

-Lisez attentivement chaque étape et suivez le bon ordre

-Séparez et comptez toutes vos pièces et matériaux

-Donnez-vous suffisamment de place pour l'assemblage

-Avoir les outils suivants: tournevis à tête plate, #2 tournevis Phillips, et Marteau

-Attention: Si vous utilisez une perceuse électrique ou un tournevis électrique pour visser, veuillez à ralentir et arrêter lorsque la vis est bien serrée. Le non-respect de cette consigne peut endommager la vis.

## Système de Fixation de Came (page 3)

Ce Système de Fixation de Came sera utilisé tout au long de l'assemblage

## Page 4

Veillez noter :

Vous devrez peut-être taper légèrement sur les chevilles en bois à insérer dans les trous pendant votre processus d'assemblage.

# Français

---

## Page 10/13

Vous devrez taper sur le connecteur (9) avec un marteau pour l'insérer complètement. Assurez-vous que le connecteur est positionné comme indiqué avant de le taper dans le trou.

## Page 21

Ne serrez pas complètement la vis.

## Page 23

**IMPORTANT! LE PANNEAU ARRIÈRE EST UNE PARTIE STRUCTURELLE DE CETTE UNITÉ ET DOIT ÊTRE INSTALLÉ CORRECTEMENT.**

Avec l'aide d'une autre personne, retournez l'appareil sur sa face avant. Positionnez le panneau arrière comme indiqué. Alignez le panneau avec les bords extérieurs. Fixez le panneau arrière aux pieds postérieurs (H&I) avec les vis (5), mais ne les serrez pas. Alignez le bord inférieur du panneau arrière avec le bord inférieur du bas et clouez-le directement dans les bords arrière du haut (C) et du bas (D). Ensuite, serrez les vis (5).

Assurez-vous que l'appareil est bien d'équerre.

La distance d'un coin à l'autre doit être identique à celle indiquée.

Assurez-vous que le bord du panneau arrière est au même niveau que le bord inférieur du panneau du bas.

## Page 24

### **Pour la maçonnerie, le béton ou d'autres matériaux de construction de murs :**

Consultez votre quincaillerie locale pour obtenir les ancrages appropriés afin de fixer solidement le support de sécurité.

**IMPORTANT :** CET APPAREIL DOIT ÊTRE FIXÉ AU MUR POUR ÉVITER QU'IL NE BASCULE. SUIVEZ CES INSTRUCTIONS POUR INSTALLER LE SUPPORT DE SÉCURITÉ ANTI-BASCULEMENT FOURNI AVEC CE PRODUIT.

### **OPTION 1 : Fixation dans un poteau mural (méthode préférée)**

À l'aide d'un détecteur de montants, localisez un montant dans le mur. Placez votre appareil contre le mur, avec le support de sécurité aligné à cet endroit. Pour faciliter le vissage, vous pouvez percer un trou pilote de 3 mm de diamètre (1/8 de po) dans le montant, à travers le support de sécurité. Enfoncez la vis dans le montant mural en passant par le support de sécurité. Serrez la vis qui n'a pas été complètement serrée à l'étape 11.

### **OPTION 2 : Fixation dans les cloisons sèches**

Placez votre unité à l'endroit souhaité contre un mur et marquez le mur à travers le support de sécurité, puis déplacez votre unité sur le côté. Percez un trou de 5 mm (3/16 de po) de diamètre dans le panneau mural. Tapez l'ancrage mural dans le trou jusqu'à ce qu'il soit au ras du mur. Mettez votre appareil en place et fixez le support mural à l'ancrage mural avec la vis. Serrez la vis qui n'a pas été complètement serrée à l'étape 11.

# Français

---

## Page 26

Remarque : Cette vue montre la disposition des trois tiroirs de gauche (façades J et L). Dans le cas des trois tiroirs de droite (façades K et M), c'est le même processus mais avec le support extérieur du tiroir du côté opposé.

Assurez-vous que les rainures des côtés des tiroirs sont centrées avec la rainure des façades de tiroirs.

## Page 28

Remarque : Vous devrez taper sur les fixations (4) avec un marteau pour les fixer solidement.

## Page 30

Fixez d'abord les glissières, puis les poignées.

## Page 31

Note : Les trous des supports de tiroir sont fendus. Les façades des tiroirs peuvent être ajustées en desserrant les vis, en effectuant les réglages nécessaires et en resserrant les vis.

Insérez les six tiroirs. Notez que le support des trois tiroirs de gauche est situé vers le milieu de la partie extérieure et que le support des trois tiroirs de droite est également situé vers le milieu de la partie extérieure.

## Page 32

### CHARGES MAXIMALES

Ce meuble a été conçu pour supporter les charges maximales indiquées. En excédant ces limites de charge, le meuble pourrait devenir instable, s'effondrer, et/ou causer des blessures graves.

AVERTISSEMENT : Risque de blessure corporelle - ne pas placer une télévision sur ce meuble. Ce meuble n'est pas approuvé pour une utilisation avec une télévision.

## Page 33

Enregistrez votre produit pour recevoir les éléments suivantes:

- \* Détails sur les nouvelles tendances - un aperçu sur les nouveautés
- \* Sondages - avoir une voix au sein de notre communauté
- \* Offres exclusives et codes promo
- \* Service de pièces de rechange rapide et facile

Pour enregistrer votre produit, visitez [ameriwoodhome.com](http://ameriwoodhome.com)

5 Étoiles

Visitez le site Web de votre détaillant local, évaluez votre produit acheté et laissez-nous quelques commentaires !

Nous tenons à offrir un grand "Merci" à tous nos clients pour avoir pris le temps d'assembler ce produit "Ameriwood Home", et de nous donner vos commentaires précieux.

Merci